

## Hedonic Shopping Experience as Work, Excitement, Fun: Analyzing Adolescents Purchasing Behavior towards Pop-Up Retail Stores

Ujala Ehsan<sup>1</sup>, Ahmad Muneeb Mehta<sup>2</sup>, Hafiz Fawad Ali<sup>1</sup>, Rabia Shahid<sup>3</sup>, Kashif Nadeem<sup>4</sup>

<sup>1</sup>Institute of Business Administration, University of the Punjab, Lahore, Pakistan; <sup>2</sup>Hailey College of Banking & Finance, University of the Punjab, Lahore, Pakistan; <sup>3</sup>Hailey College of Commerce, University of the Punjab, Lahore, Pakistan; <sup>4</sup>NUML, Islamabad, Pakistan

### Abstract

The purpose of the quantitative research was to analyze three objectives: (1) to analyzing of youngster's hedonic shopping experience with dimensions of adventure shopping and gratification shopping, (2) analyzing youngster's attitude towards pop-up stores and (3) to examine youngsters buying behavior towards pop-up retail stores. The data were collected from 338 students in the University of the Punjab. The data were collected using a close-ended questionnaire. The quantitative research method was used in this current study. Data were collected through self-administered questionnaire from Punjab University Lahore Pakistan. IBM AMOS and SPSS were used for analysis. It is concluded that hedonic shopping experience, youngsters buying behavior, and attitude are positively related to each other. This research has certain limitation as perusing convenience sampling. Future research may try to overcome such shortcomings. This research had concentrated only on teenagers and has not considered other individuals. Furthermore, this study was carried out mainly on students of the University of the Punjab. This was a demographical limitation. Other age groups may have different approaches. This study was conducted solely in Lahore, Pakistan. Other cities and provinces were not focused upon. By considering the results of this study, the study requires the important maintenance in the literature of PURS ideas. This research will be supportive for scholars, merchants, traders and publicizing specialists. This research will add value to the existing literature and will provide help to recognize the Youth Buying Behavior via youth attitude. The outcomes of this study showed the significance and non-significance between the mediating relationships of attitude.

**Keywords:** Pop-up stores, HSE, ATPUS, and YBB

### Introduction

Pop-up stores defined as an experiential retailing and practice or any experience which is short-term and considered as a pleasure shopping for consumers (Barras, 2016). Pop-up stores more clearly defined as a transitory shop space of the items which could be goods or services for short period of time, it might be food cafes, fashion stores or street vendors etc. (The Centre for Economics and Business Research, 2015). Pop-up stores has clearly defined his starting and closing date, everything moved and changed according to the fashion and situation that goes on in the marketplace (Department for Communities Local Government and Association of Town Centre Managers, 2013). The retail industry always practice to the expansion and growth of the industry and never remained constant for some time period, due to the technology advancement and usage of internet changes the consumer buying behavior towards shopping, e-shopping become more advance shopping and became the retail industry more competitive (Grewal, Roggeveen, & Nordfalt, 2017). It is a part of consideration that consumer buying behavior has changed very vastly and consumer seeking out entertainment shopping experiences and find pleasure from shopping (Chen & Fiore, 2017; Niehm, Fiore, Jeong, & Kim, 2007). Now-a-days, consumers consume improved goods and services in order to fulfil their better needs and wants of standard life (Chen & Fiore, 2017). On the other

hand, 72% consumers like to buy their daily need products from stores and prefer good store experience (Wallace, 2016). Pakistan's population is approximately around 196 million, Pakistan retailing industry has continuously changed and getting better day by day in order to compete with others. The demand of pop-up stores has not only increased in the other countries but also trendy in Pakistan retail industry. It is a part of evidence that young generation is more indulged to purchase the goods and services through pop-up fashion stores, they are also called youngsters. New fashion is adopted very fast in urban areas of Pakistan where hypermarkets are full of citizens, some metropolitan cities in Pakistan like Karachi, Islamabad and Lahore. Retail sector in Pakistan is almost of 4.2 billion worth, and specify 18% GDP (PBS, 2011-12), nearly two million merchandising network in Pakistan. Since those retail networks around eight lac channels specify the FMCG with some minor network retail channel like kiryana shops. Pop-up stores are minor in Pakistan and managed through individuals in their convenience site near to satisfy the customer's day-to-day desires and requirements. Experiential retailing is one example of pop-up stores, it is considered as innovative marketing strategy and this strategy has been established by different behaviors since indulgence supplies e.g. Louis Vuitton, department stores e.g. Target, (Ryu, 2011). For instance, Kate Spade released a pop-up stores in the SoHo and only dealt with home accessories in New York (Hargrove, 2016). The present study only concentrated on pop-up fashion stores and analyzing the YBB towards PUFs. This research study removed the literature slit.

There existed a resulting study hypothesis of this current study:

- H<sub>1</sub>.** HSE has a connection with ATPUS.
- H<sub>2</sub>.** ATPUS has a connection with YBB.
- H<sub>3</sub>.** HSE has a connection with YBB.

**Theoretical Framework**

The theoretical framework for this research is as follows. The dependent variable is on the right-hand side and it is being affected by the mediating variable that is Attitude. The mediation variable is being affected by the independent variables.

**Dependent variable:** Youngsters Buying Behavior

**Mediator:** Attitude

**Independent Variable:** YBB

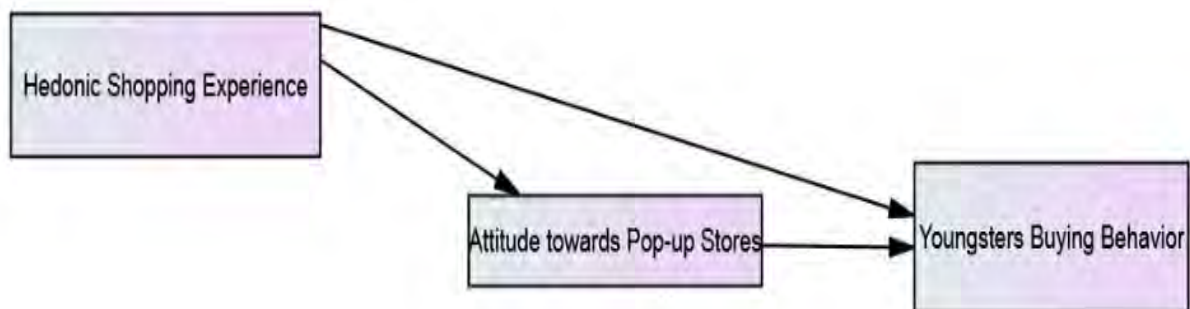

**Figure 1: Theoretical Framework**

Pop-up stores also measured as HSE that gives pleasure and amusement shopping experience to consumers (Kim et al., 2010; Niehm et al., 2007), consumers who are always seeking fun from shopping, pop-up stores shopping experience is best for them. In the modern and technology era, buyers always ready for new shopping experience i-e, hedonic shopping that becomes very popular and extend very widely in the retail industry (Kim et al, 2007). Pop-up stores increase the independence level of consumer shopping behavior such as they look for pleasant, invented new shopping experience for fulfilling their desires (Kim et al, 2007). The hedonic shopping experience has six dimensions (Arnold & Reynolds, 2003), (1) adventure shopping, (2) social shopping, (3) gratification shopping, (4) idea shopping, (5) role shopping, and (6) value shopping. Two dimensions of hedonic shopping experience were discussed in the present study, (1) adventure shopping experience (2) gratification shopping experience

**Adventure shopping experience.** It is a kind of shopping experience which is different from the normal shopping experience, it gives pleasure and fulfills the desires and makes shopping more exciting. It described adventure shopping as encouragement, creativeness, and passion for shopping is called adventure shopping experience. In these days, youngsters find out excitement and prefer to do shopping from pop-up stores and also they want to increase their sensational feelings through imagination. Youngsters are the generation ready to try new things from new shopping experience (Park et al., 2006).

**Social shopping.** It is a type of shopping experience where friends and family make shopping more excited, it is called societal spending experience. It is a strategy done by informally cooperating individuals in the social circle that can be friends, family, and communally interacted people.

**Fulfillment shopping.** It is a type of shopping experience that makes the customers stress free and change their mood happy and towards a positive attitude, it is also called gratification shopping experience (Hausman, 2000).

**Idea shopping.** It is the shopping experience, comprised of new and latest fashion which are going on in the market.

**Role shopping.** It is a shopping experience in which consumers resolve the problems of shopping for others.

**Value shopping.** It is the type of shopping experience in which adult seek out deals and enjoyable shopping experience is known as value shopping experience (Arnold, 2003).

Attitude defined in the present study, as a person overall personality evaluation to pop-up stores is recognized as attitude (Fishbein & Ajzen, 1975). Having deep knowledge about pop-up stores, it is important to appreciate the attitude of YBB to pop-up fashion stores first, having profound knowledge about consumer's attitude makes the market more competitive. Consumer's decision-making style also important to understanding the consumer attitude towards shopping (Burns, 2011). Age, gender, monthly income, family background and consumer's professions also important for marketers and retailers to understand the profile of consumers (Wang, Siu, & Hui, 2004). These are important demographics factors to understand the attitude of consumers but not sufficient to understand the in-depth and profound knowledge about consumers attitude towards pop-up fashion stores because each individual has different attitude and personality towards spending arrangement, shopping orientation because of different behavior (Wang et al. Warn, 2004). According to Wang et al., (2004), earlier researches suggested analyzing the youngsters buying behavior in decision-making style and their attitude towards pop-up stores by offering significant consideration. By having the knowledge about consumer's attitude, retailers and marketers can get help and identify the consumer choices and preferences more efficiently and test the market and make their strategy successfully implement in the competitive marketplace (Burns, 2011). The present study, analyzing the youngsters buying behavior of hedonic shopping experience towards pop-up fashion stores. Accord-

ing to the previous study, Sproles & Kendall eight consumer attitude about decision-making style had identified which were;

High-quality aware consumers/perfectionist. In this type of attitude, consumer searched high-quality level products and services as well.

Brand awareness/ price equals excellence. This attitude comprised of high quality and consumers prefer to buy a famous brand. This type of consumer's attitude is considered as high prices and superior quality.

Innovation and style awake. Young consumers usually seek out reinvented and technologically innovative products and they feel happy from searching the new and innovative products.

Entertaining and shopping aware. A consumer shopping attitude comprised of shopping as a joyful activity and buy products for the sake of pleasure and happiness.

Value cognizant. A buyer attitude to aspire from sales advertising campaign and this type of consumer's attitude prefer to purchase discounted items.

Impulsiveness /unthinking. A consumer attitude to purchase the items for the incentive of instant and they look unworried about spendings. They considered themselves as the best buyer.

Confused by over-choice. A consumer attitude as they always confused from so many choices and brands and these type of consumers also have too many experience and information about brands in the economic marketplace. These were the succeeding attitudes which deliberated by the earlier researchers. The present study investigated the over-all assertiveness of YBB to pop-up stores. From 50 years earlier, youth considered as the most socially aware generation than other generation (Meister & Willyerd, 2010) and youngsters are not only presented the latest value but also have indulged with traditional values (Brosdahl & Carpenter, 2011). The young generation has unique characteristics as they have socially connected in society (Pokrywczynski & Wolburg, 2001). There were following seven characteristics of youngsters (Howe & Strauss, 2007), (1) exceptional, (2) self-serving, (3) confident, (4) work-oriented, (5) analytical (6) compelled and hassled, (7) successor. The young generation is more goal-oriented, socially aware and optimistic generation as others (Farris et al., 2002). Youngsters are the generation they changed fashion very firstly because of the technological world and more awareness about products (Bakewell & Mitchell, 2003). A young generation always prefers to purchase new and innovative products that shopping becomes a source of pleasure and entertainment for them (Kol & Lissitsa, 2016). Pop-up retailing as an innovative and new entertaining marketing strategy by giving elusive and presented new items with an enjoyable atmosphere (Huffelen, 2016). Evidence suggested by one study, 70% of females of the city resident dedicated to entertaining and new fashion oriented and 50% young males also dedicated to entertaining shopping experience (Krueger, 2005). In the technology era, the young generation is more encompassed by social media and celebrity styling for their fashion perspective.

### **Methodology**

Quantitative research had been used in the current study. Deductive approach and a cross-sectional survey have been used. The data is collected from different departments of University of the Punjab Lahore Pakistan through a self-administered questionnaire. The total population of the present study was 2800 students. Only the young generation was targeted because their purchasing and buying behavior towards pop-up fashion stores are more emotional than other generation nowadays. Non-probability convenient sampling technique has been used in this current study. Data collected from sampling by using convenience sampling. Survey study has been done in this study and divides into 6 segments, in the first section, demographic evidence attained such as gender, age, marital status, family background, department, qualification, and scheduled domestic income. The

measuring tool of hedonic shopping experience adopted from (Babin, 1994) with two dimensions such as adventure shopping experience and gratification shopping experience. youngsters buying behavior variable adopted by (Niehm, 2007). 5-point Likert scale was used to test the self-administered questionnaire. (1) Strongly agree to (v) Strongly disagree with IBM SPSS 22 & AMOS 22 and excel 2013 had been used to analyze the test of this current study. Overall Conformity factor analysis (CFA), measurement model and SEM model has been tested through AMOS. Hedonic shopping experience of conformity factor analysis was above .3 it showed the model is a good fit. The value of CFA of youngsters buying behavior and attitude was also above from .3 as well.

## Results

### *Demographic Profile of Respondents*

In the current study, the sample size was 338 respondents in which 150 were male which is showing 44.4 percentage and 188 were female which is showing 55.6 percentage.

#### *Gender*

**Table 1. Gender Frequency**

		Frequency	Percent	Valid Percent	Cumulative Percent
Valid	Male	150	44.4	44.4	44.4
	Female	188	55.6	55.6	100.0
	Total	338	100.0	100.0	

Data was gathered from the respondents of different age groups ranging from 15 years to 28 years 20-24 years. 25-27 years and 28 years or above.

#### *Age*

**Table 2. Age Frequency**

		Frequency	Percent	Valid Percent	Cumulative Percent
Valid	15-19	95	28.1	28.1	28.1
	20-24	211	62.4	62.4	90.5
	25-27	24	7.1	7.1	97.6
	28 & above	8	2.4	2.4	100.0
	Total	338	100.0	100.0	

#### *Marital Status*

**Table 3. Marital status**

		Frequency	Percent	Valid Percent	Cumulative Percent
Valid	Single	307	90.8	90.8	90.8
	Married	31	9.2	9.2	100.0
	Total	338	100.0	100.0	

Among 338 participants the people who were married were only 31 i.e. 9.2 % only. The lion's share was of people who were unmarried i.e 90.8%.

Correlation Analysis

**Table 4. Correlations**

		HSE	ATPU	YBB
HSE	Pearson Correlation	1	.708**	.661**
	Sig. (2-tailed)		.000	.000
	N	338	338	338
ATPU	Pearson Correlation	.708**	1	.670**
	Sig. (2-tailed)	.000		.000
	N	338	338	338
YBB	Pearson Correlation	.661**	.670**	1
	Sig. (2-tailed)	.000	.000	
	N	338	338	338

\*\* . Correlation is significant at the 0.01 level (2-tailed).

Confirmatory Factor Analysis

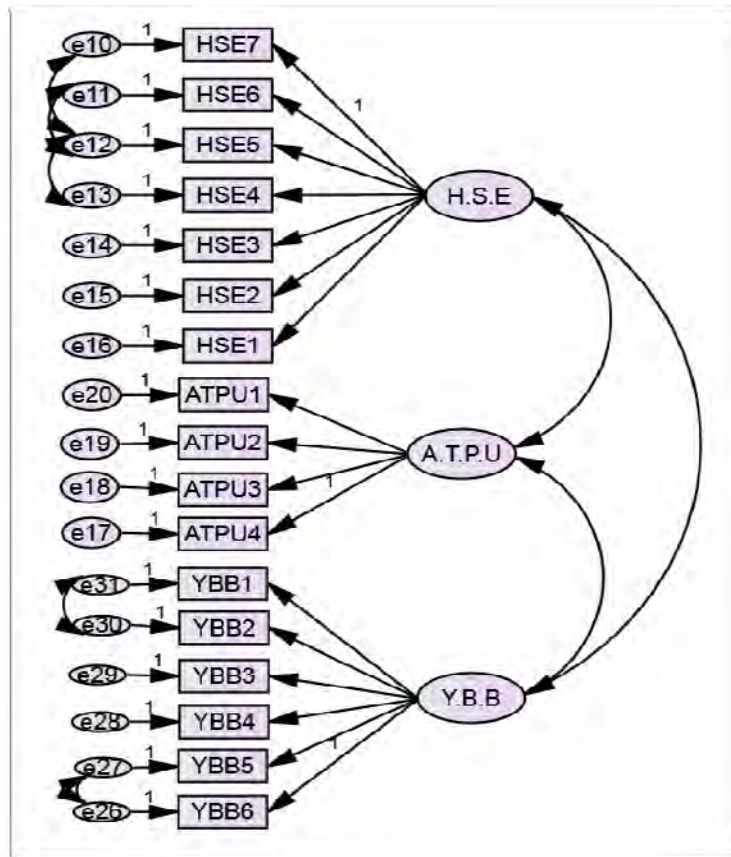

**Figure 2. CFA**

*Fitness Summary*

**Table 5. Fitness Summary**

CMIN/DF	CFI	GFI	AGFI	RMSEA	PCLOSE
2.209	.929	.910	.885		

The value of CFI, CDMIN, GFI, RMR, and RMSEA has been encountered the acceptable standard.

**Table 6. Standardized Regression Weights**

			Estimate
ATPUS4	<---	A.T.P.U	.688
ATPUS3	<---	A.T.P.U	.736
ATPUS2	<---	A.T.P.U	.817
ATPUS1	<---	A.T.P.U	.785
YBB6	<---	Y.B.B	.580
YBB5	<---	Y.B.B	.669
YBB4	<---	Y.B.B	.689
YBB3	<---	Y.B.B	.720
YBB2	<---	Y.B.B	.739
YBB1	<---	Y.B.B	.749
FI1	<---	F.I	.542
FI2	<---	F.I	.584
FI3	<---	F.I	.645
FI4	<---	F.I	.388
FI5	<---	F.I	.628
FI6	<---	F.I	.638
FI7	<---	F.I	.693
FI8	<---	F.I	.650
FI9	<---	F.I	.651

Above table shows that all factor loading is greater than .3.

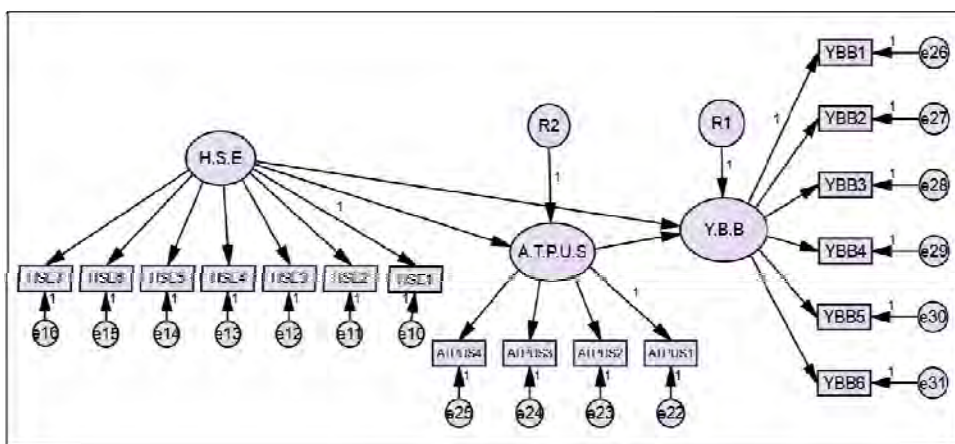

**Figure 3: Structural Equation Model**

The value of the average variance extracted of hedonic shopping experience was .66, and ATPU was .75, and YBB was .69. Average variance extracted of variables were larger than .5 thus it showed a worthy CV of variables. HSE of Cronbach Alpha, (ATPU) and (YBB) was higher than .5 which showed the high internal reliability in the current study.

**Table 7. Standardized Regression Weights: (Group number 1 - Default model)**

			Estimate	P-value
Y.B.B	<---	H.S.E	.902	0.001
A.T.P.U	<---	Y.B.B	.502	0.001
A.T.P.U	<---	H.S.E	.754	0.001

*Mediation*

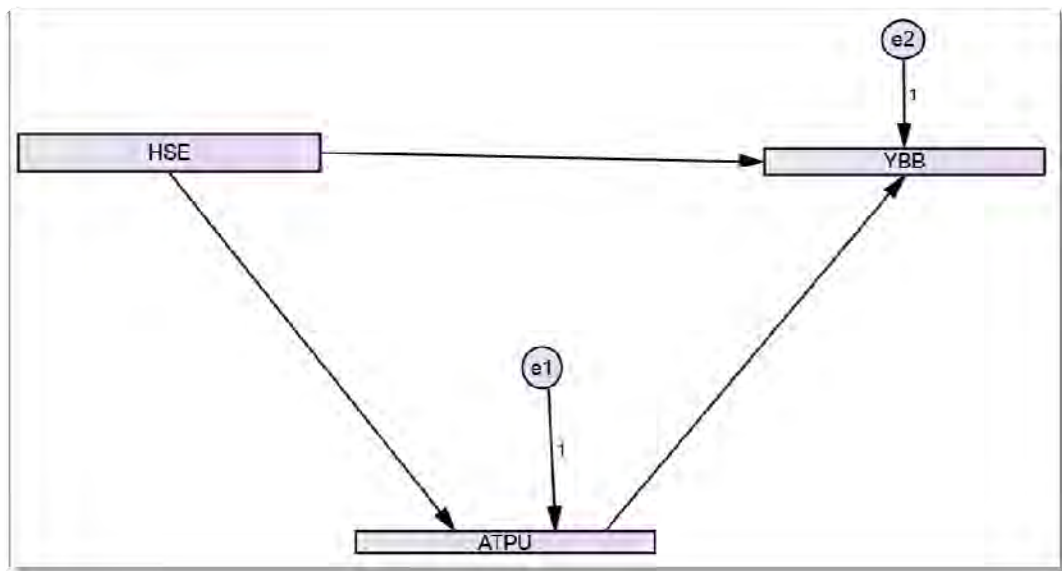

**Figure 4. Mediation**

*Mediation Analysis*

**Table 8. Mediation Analysis**

Direct Beta without Mediation	Direct Beta with Mediation	Indirect Beta	Results
.902***	.754***	.182***	Partial Mediation

**H<sub>1</sub>. Hedonic Shopping Experience has an affirmative association with ATPUS**

HSE showed an optimistic outcome between the mediating roles of ATPU. By means of per p-value stayed .000 was less than .05 and the worth of coefficient is .583 it existing the positive significant relationship. As per the value HSE increases by one unit then the mediating role between ATPUS is expected to rise via .583 components.

**H<sub>2</sub>. ATPUS has an optimistic association with YBB**

YBB showed the optimistic outcomes between the mediating roles of ATPUS. By means of p-value was .000 is a smaller than .05 and coefficient value is .299 it presented that the optimistic



noteworthy association. By means of the value of ATPU growths by single element then YBB is predictable to growth by .299 items.

### **H<sub>3</sub>. HSE has an optimistic connection with YBB**

HSE showed the progressive connection between YBB. By means of p-value was .000 was less than .05 and coefficient value is .024 presented the optimistic association. By way of the value of HSE rises by 1 part then the value of YBB is predictable to surge through .024 elements.

### **Managerial Implication and Recommendation**

The research investigation paid key importance to the previous literature of PURS of consumer hedonic shopping experience and their attitude. The outcomes of this study showed the significance and non-significance between the mediating relationships of attitude. The current study has presented an important contribution for the retailers, marketers and business experts. This is a new innovative marketing strategy to examine the young generation buying behavior towards fashion stores, this study will be very helpful for the retailers to compete in the market. It will also provide profound knowledge about consumer's attitude. There is a certain limitation also. The current study has only considered the young generation. Future researchers can extend this research by using other variables. The mediating role of other variables can also be checked. The current study has only used quantitative research, the future researcher can also use qualitative research method in order to gain more knowledge about pop-up fashion retail stores.

### **Conclusion**

Retailing industry has become more successful and vast in these days due to the internet and technological reformed world. Consumer is more aware of products due to internet usage. The current study has examined the youngster buying behavior of hedonic shopping experience and their ATPUS. Thus the outcomes of research investigation found that Hedonic shopping experience had a positive relationship with the youngster's attitude. ATPUS had a positive relationship with the YBB. HSE had a positive relationship with YBB concerning PUS.

### **References**

- Arnold, M.J. & Reynolds, K.E. (2003). Hedonic shopping motivations. *Journal of Retailing*, 79(2003), 77-95.
- Babin, B. J., Darden, W. R., & Griffin, M. (1994). Work and/or fun: Measuring hedonic and utilitarian shopping value. *Journal of Consumer Research*, 20(4), 644-656.
- Bakewell, C., & Mitchell, V. W. (2003). Generation Y female consumer decision-making styles. *International Journal of Retail & Distribution Management*, 31(2), 95-106.
- Beaudoin, P., Lachance, M. J., & Robitaille, J. (2003). Fashion innovativeness, fashion diffusion and brand sensitivity among adolescents. *Journal of Fashion Marketing and Management*, 7(1), 23-30.
- Beaudoin, P., Moore, M. A., & Goldsmith, R. E. (1998). Young fashion leaders' and followers' attitudes toward American and imported apparel. *Journal of Product & Brand Management*, 7(3), 193-207.
- Burns, D. J. (2011). Consumer decision-making styles: Relationships with consumer alienation. *Journal of Business and Retail Management Research*, 6(1).
- Centre for Economics and Business Research (2015). Britain's pop-up retail economy. Retrieved from [www.cebr.com/wp-content/uploads/2015/08/EE-Pop-Up\\_Retail\\_Economy\\_Report.pdf](http://www.cebr.com/wp-content/uploads/2015/08/EE-Pop-Up_Retail_Economy_Report.pdf).
- Chen, W. C., & Fiore, A. M. (2017). Factors affecting Taiwanese consumers' responses toward pop-up retail. *Journal of Marketing and Logistics*, 29(2), 370-392.

- Fishbein, M., & Ajzen, I. (1975). *Belief, Attitude, Intention and Behavior: An introduction to theory and research*. Addison-Wesley.
- Grewal, D., Roggeveen, A. L., & Nordfält, J. (2017). The future of retailing. *Journal of Retailing*, 93(1), 1-6.
- Hargrove, C. (2016, March 8). You're going to want to live inside this Kate Spade pop-up shop. Retrieved from <http://ny.racked.com/2016/3/8/11180062/kate-spadehome>
- Hausman, A. (2000). A multi-method investigation of consumer motivation in impulse buying behavior. *Journal of Consumer Marketing*, 17(5), 403-419.
- Howe, N., & Strauss, W. (2007). The next 20 years. *Harvard Business Review*, 85(8), 41-52.
- Huffelen, W. (2016). Why pop-up stores are great for millennials. Go pop-up. Retrieved from <http://www.gopopup.com/magazine/why-pop-up-stores-are-great-for-millennials>.
- Im, S., Mason, C. H., & Houston, M. B. (2007). Does innate consumer innovativeness relate to new product/service adoption behavior? The intervening role of social learning via vicarious innovativeness. *Journal of the Academy of Marketing Science*, 35(1), 63-75.
- Johnson, L. (2011). New marketing concept promises to re-shape the retail landscape in SA. Retrieved from [http://www.themarketingsite.com/live/content.php?Item\\_ID=13087&Revision=en%FO&Start=0](http://www.themarketingsite.com/live/content.php?Item_ID=13087&Revision=en%FO&Start=0)
- Keller, M., & Kalmus, V. (2009). What makes me cool? Estonian tweens' interpretative repertoires. *Journal of Young Consumers*, 10(4), 329-341.
- Kim, Y. K., Sullivan, P., & Forney, J. A. C. (2007). *Experiential retailing: Concepts and strategies that sell*. Fairchild Publications.
- Kirton, M. (1976). Adaptors and innovators: A description and measure. *Journal of Applied Psychology*, 61(5), 622.
- Lissitsa, S., & Kol, O. (2016). Generation X vs. Generation Y—A decade of online shopping. *Journal of Retailing and Consumer Services*, 31, 304-312.
- Meister, J. C., & Willyerd, K. (2010). Mentoring millennials. *Journal of Harvard Business Review*, 88(5), 68-72.
- Morton, L. P. (2002). Targeting generation Y. *Public Relations Quarterly*, 47(2), 46.
- Niehm, L. S., Fiore, A. M., Jeong, M., & Kim, H. J. (2007). Pop-Up retail's acceptability as an innovative business strategy and enhancer of the consumer shopping experience. *Journal of Shopping Center Research*, 13(2), 1-30.
- Ryu, J. S. (2011). Consumer attitudes and shopping intentions toward pop-up fashion stores. *Journal of Global Fashion Marketing*, 2(3), 139-147.
- Sproles, G. B., & Kendall, E. L. (1986). A methodology for profiling consumers' decision making styles. *Journal of Consumer Affairs*, 20(2), 267-279.
- The Department for Communities and Local Government (2013). *New opportunities for sustainable growth and development through the reuse of existing buildings*, Retrieved from available at: [www.gov.uk/government/uploads/system/uploads/attachment\\_data/file/197684/New\\_opportunities\\_for\\_sustainable\\_development\\_and\\_growth\\_through\\_the\\_reuse\\_of\\_existing\\_buildings\\_summary\\_of\\_responses.pdf](http://www.gov.uk/government/uploads/system/uploads/attachment_data/file/197684/New_opportunities_for_sustainable_development_and_growth_through_the_reuse_of_existing_buildings_summary_of_responses.pdf).
- Wang, C. L., Siu, N. Y., & Hui, A. S. (2004). Consumer decision-making styles on domestic and imported brand clothing. *European Journal of Marketing*, 38(2), 239-252.
- Wolburg, J. M., & Pokrywczynski, J. (2001). A psychographic analysis of Generation Y college students. *Journal of Advertising Research*, 41(5), 33-52.