

The Role of Renewable Energy in Decreasing Environmental Pollution

Mehdi Paktinat*, Saeid Ghods, Mohammad Hussein Najm al-Din

Electricity Distribution Company of Semnan Province, Semnan, Iran

*E-mail: m_paktinat@ymail.com

Abstract

Using renewable energy is one of the most important problems of the world and among renewable energies, biomass is considered as the first position in supplying the global energy so that more than 10% of supplying global primary energy is provided by biomass resources. In the field of power generation from renewable sources, after water energy, biomass is in the second place which is allocated 6% of global share in 2000 and in a new step followers of renewable energy use, it is going to recycle concrete rubble by lightning and every year, thousands tons of concrete rubble are created by renovation of roads and destruction of old buildings. In recent years, more than a million tons of construction waste is produced which is regarded as another factor for the reduction of the environmental pollution.

Keywords: renewable energy, biomass, recycle of concrete rubble by lightning

Introduction

Energy is the main source of human life, especially today when we face to energy sources reduction in our country. Various periods of human civilization are shaped based on the discoveries and inventions and how to utilize the available various energy sources. Therefore, the energy discussion can be considered as the base and foundation of today's social life. Researches and innovations and the use of different energies are the most essential and important steps that human have taken in the development of their societies throughout the history. Traditional energy sources, fossil fuels and electricity derived from nuclear gap actually dominate the energy supply system in today's world, but the intense dependence of industrial societies on fossil fuel resources, particularly oil and gas and indiscriminate use of them may vacate the great resources that are formed in lower layers of the earth over the centuries. Considering that the underground energy resources are used with tremendous speed and they will vanish in not too far future, the current generation should refer to the energy sources with high life and potential and should expand their knowledge to utilize them. Another important feature that attracts human's attention to renewable energy or in other words clean fuels refers to the discussion of environmental pollutions caused by excessive consumption of fossil fuels and their irreparable dangers and damage to the human society. The atomic waste caused by atomic power plants is one of the great problems of today's human. In addition, highly advanced technology to utilize the nuclear energy and also the high cost of these systems in duplicated form is other barriers of the nuclear energy application. So, the clean energies should be used and the waste produced by existing energies resources should be reduced. The recycle of concrete rubble by lightning is one of the most important problems that, in addition to the cement consumption and great waste production leading to the air pollution as well as the Earth planet warming. Cement producers are responsible for creating 8 to 15% of global carbon dioxide. There should be a way to reduce pollution which has had the least pollution that is explained in this article.

Definition of biomass

A gas is obtained in one compartment by applying a variety of physical - chemical and environmental processes on various sources of biomass such as analysis and fermentation and so on which is called biogas. After a series of purification processes in accordance with the global and environmental standards on this gas, it can be considered as an energy carrier. This carrier can be

used directly and also as the primary fuel in power plants. By gas fueling, turbine and generators move and produce electricity at all existing power plants similar to the common traditional cycles. The only difference is that this time not only the required fuel to the boiler has not been extracted from the earth but also the environmental and humanistic pollution is prevented with optimal application. A wide range of industries and existing systems can be set up by directly applying this gas and consequently saving the valuable fossil fuels resources such as oil, gas and so on.

First of all, it is better to consider the organic concept of biomass. Every living organism that absorbs solar energy and stores it is called biomass. Biomass is a term that is used in the field of energy to describe the range of products that are obtained from photosynthesis act. Every year, through photosynthesis equal to the several times of annual consumption of global energy, solar energy is saved in the leaves and branches of trees. Therefore, among the renewable energy sources, biomass is unique for storing solar energy. Moreover, biomass was only renewable source of carbon and can convert to the appropriate solid, liquid and gas fuels. Even hydrogen which is one of the crucial products in the energy sector can be achieved by applying a series of chemical operations on biogas derived from biomass. Biomass is mostly in the shape of wood namely the oldest form of energy which is used as fuel for domestic and industrial purposes which was initially used by using the direct combustion method, a process which is still widely used in various parts of the world. The use of biomass as an energy source, not only for economic reasons but also because of social and economic and environmental development reasons is also attractive. Systems that convert biomass to consumable energy have also the ability to convert to small systems. Agriculture and forestry industry are basic resources of biomass. The emission rate of pollutants materials derived from biomass combustion is typically less than fossil fuels. Additionally, the commercial exploitation of biomass can eliminate or reduce the difficulties relevant to the waste disposal in other industries such as forestry and wood products, food processing, especially municipal solid waste in urban centers. Biomass resources which are suitable for energy production including a wide range of materials that are generally divided into six groups including wood fuels, forest, agriculture, horticulture and food industries wastes, Solid waste of urban sequences, livestock manure, urban waste water, and industrial organic wastewater, residuals and wastes

Biogas can also be achieved by existing methods and techniques for the waste disposal in the underground that by purification of obtained gas, this gas can be applied in all industries, especially as biolar fuel in power plants.

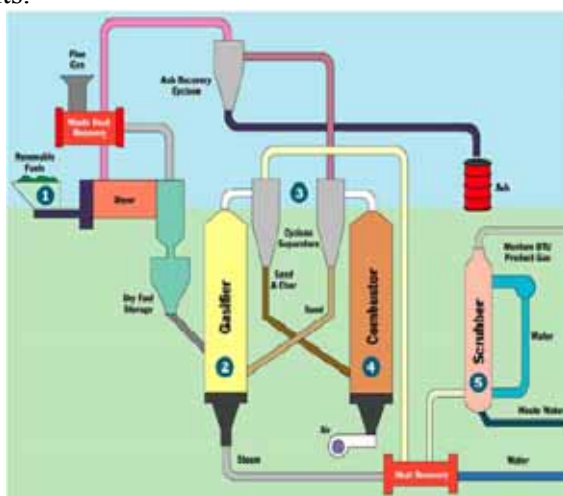

Figure 1. Biolar fuel in power plants

Biogas applications

Biogas can be used in various ways that each one requires separate demands and in all status the installation of the system of transferring pipes, control faucets and measurement meter is essential. We can refer to a variety of biogas applications such as gas ovens, biogas lamps, radiant heaters, biogas-fired water heater, biogas-fired fridge and engines.

Recycle of concrete rubble by lightning

Initially, the required lightning should be produced. Available methods are so limited to recycle the concrete that generate large amounts of dust but recycling by lightning energy is the only way having less pollution than other methods. To do this, at first we discuss lightning. Nowadays, the generation of lightning waves in high voltage laboratory is common because all high voltage equipment should be tested by impulse waves prior to the installation on site. The following figure displays the single-stage shock wave generator circuit. In this circuits, capacitor C1 is charged through DC source to the breakdown voltage of the two electrodes (two balls). The mentioned spark electrode acts as a voltage-sensitive key. Resistors of R1 and R2 and network C2 capacitor are made to compose the waveform. R1 was the main damping of circuit and controls frontal wave's time. R2 controls the behind time of the wave to discharge the capacitors of employed circuit. Capacitor C2 models the load and tests the device and all capacitors in parallel with it like the measuring device. In this model, the maximum energy stored in the capacitor C1 is as an important parameter:

$$W = \frac{1}{2} C_1 (V_{0_{max}})^2 \tag{1}$$

Figure a:

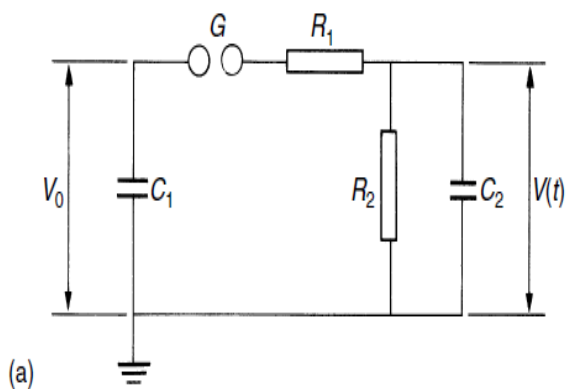
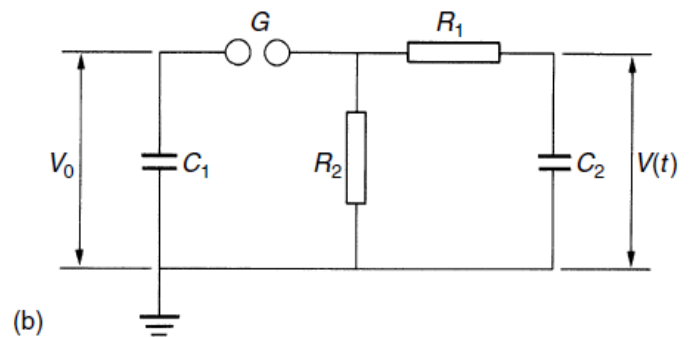
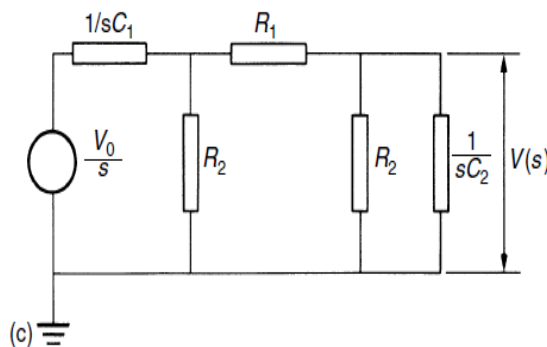

Figure b:



Circuit Analysis b:



The output of voltage is:

$$V(s) = \frac{V_0}{s} \frac{Z_2}{Z_1 + Z_2}, \quad (2)$$

And Z1 and Z2 are:

According to the mathematical equations:

$$Z_1 = \frac{1}{C_1 s} + R_1; \quad (3)$$

$$Z_2 = \frac{R_2 / C_2 s}{R_2 + 1 / C_2 s}.$$

$$a = \left(\frac{1}{R_1 C_1} + \frac{1}{R_1 C_2} + \frac{1}{R_2 C_2} \right);$$

$$b = \left(\frac{1}{R_1 R_2 C_1 C_2} \right); \quad (4)$$

$$k = R_1 C_2.$$

$$V(s) = \frac{V_0}{k} \frac{1}{s^2 + as + b} \quad (5)$$

Similarly for circuit of figure (a) we have:

$$a = \left(\frac{1}{R_1 C_1} + \frac{1}{R_1 C_2} + \frac{1}{R_2 C_1} \right); \quad (6)$$

$$b = \left(\frac{1}{R_1 R_2 C_1 C_2} \right); \quad (7)$$

$$k = R_1 C_2. \quad (8)$$

For both circuits by using the inverse Laplace transform, we have: $\alpha^1 \alpha^2$ and the roots of the equation are $S^2 + aS + b$. According to the obtained equation wave V (t) is the sum of two exponential functions:

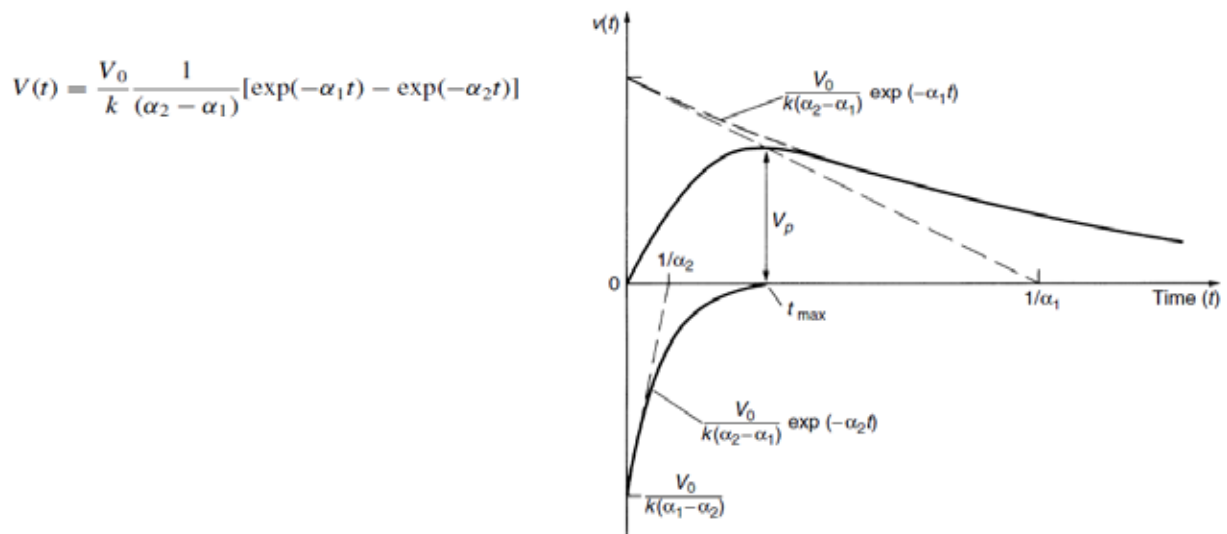

Lightning can pass through water or air, but there is a way to pass the thunder of solids. Lightning passes through water in a very short time about 500 ns and enters into a solid material. In the next step, the concrete should be known. Concrete has five special types with different grades. At first, the concrete strength should be found in testing laboratories. After performing all these steps, the amount of energy that has shattered should be found with regard to the strength of concrete and then this energy generator produces high voltage energy in testing laboratory, then this energy is led to the container with concrete. Lightning, while dealing with concrete rubble, passes with minimal resistance through stone and sand leading to the separation of the concrete to its components resulting in maximum recycle. Now, a bit of concrete is obtained in a strong relationship

The scope of application

This test refers to the compressive strength determining method of cylindrical concrete specimens such as cylindrical cores or samples provided by cylindrical molds. This method is used for concretes that their specific weight is more than 800 kilograms per cubic meter.

Importance and application

Because the resistance for concrete made with certain materials is not an inherent property, the importance of determining the compressive strength should be emphasized. The obtained values depend on the resistance in the sample shape, its dimensions, the mixing method, the operation method, sampling method, molding method, method of construction and sample's age.

Methodology

Compressive samples that are made under the moisture should be tested as soon as possible after extracting from the humidity room. Tested samples should be kept moist by a simple way in a distance that it is extracted from humidity room until performing the test and should be put to the test in wet conditions.

Sample and materials

If the diameter of the sample in one part differs more than 2% with its diameter in another part, it should not be tested. The bottom of sample should not be deviated more than 5.0 degrees from the stretches of perpendicular to its axis (approximately 3 mm in 300 mm). While two ends of

the sample to be rougher more than 0.05 mm. Regarding the tool, testing machine is used, having sufficient capacity with loading speed.

Conclusion

Compressive strength of sample is determined by dividing the maximum load applied to its articulated surface. If the ratio of diameter to sample length to be less than 1.8, the obtained result can be corrected by applying the following coefficients:

Table 1. Results of coefficients

| | | | | |
|-------------|------|------|------|------|
| L/D | 1/75 | 1/50 | 1/25 | 1/00 |
| coefficient | 0/98 | 0/96 | 0/93 | 0/87 |

Therefore, by considering the above table, it is necessary to pay attention to two issues: First, if the strength of cement is not calculated accurately, either cement burns or does not have any effect. Second, resistance value should be expressed in terms of cubic meters and container should be in accordance with it. After performing the separation, cement which is lighter can be separated by evacuator and sand is removed from the other side.

References

- Glouer, J.K. (1996). Power system design, USA.
- Nekrasov, A.M. (1997). Design and development of power, transmission and substation.
- Siemens, A. (1982). Substations and elements, Wasserkraft.
- Transmission line reference book (1992). Electric power research, USA.
- http://www.irancivilcenter.com/fa/articles/view/?article_id=64
- <http://zohrab10.blogfa.com>
- <http://www.hamkelasy.com/content/view/145/43/>
- http://lightweightconcrete.persianblog.com/1385_7_Light