

## An Evaluation of Quality Improvement Methods Regarding Output Power of Wind Plants` Inverters

**Farshid Norozi, Mohsen Zanganeh**

NEWCASTLE University School of Electrical, Electronic and Computer Engineering

E-mail: [Mz52436@outlook.com](mailto:Mz52436@outlook.com)

Received for publication: 14 October 2014.

Accepted for publication: 27 February 2015.

### Abstract

Today, with respect to the problems derived from non-renewable energy such as environment pollution, increasingly growth of fossil fuels` costs and the process of running out of sources; using renewable energies has been highly considered. Meanwhile, wind energy has widely been utilized. Integrating wind energy within power systems minimizes their effects on environment while connecting wind generation systems within power systems causes technical challenges such as the problems related to power quality, voltage regulation and sustainability where power quality is of highest importance. The present study attempts to evaluate the methods of improving inverters` quality in wind plants. To this purpose, “Space vector pulse width modulation”, “using STATCOM” and “using UPQS” to improve power quality are discussed.

**Keywords:** power quality, inverter, wind plant

### Introduction

During the recent years, renewable energy sources have been considered by researchers due to the limited fossil fuels and the resulted environmental pollutants so that many countries seek to allocate 5 to 25 percent of their generating power system capability to renewable energies (Arulampalam, et al. 2006). Wind among renewable energy sources have been considered as a clear energy source. Wind energy unlike many other renewable sources, has the ability to generate electrical energy widely through installing wind turbines. It has caused that wind turbines more than other power generation technologies, based on new energies is able to compete with conventional generators and their application can be increased in small size stand-alone systems and in large inter-connected power systems(Kwasinski, 2003).

Wind plants are considered as a new domain based on their efficient experiences and are expanding increasingly in European countries. The most important advantage of generating power from new energies is the lack of releasing toxic particles and unlimited sources used as primary driving force (Amin, 2004).

Nowadays, most of the necessary electrical energy are generated in fossil plants in the world. Detrimental environmental effects stemmed from fossil fuel plants, decreasing fuel sources, skyrocketing prices of fuel and generated energy cost make consumers to use renewable sources. The main part of energy generates from renewable sources through water and wind plants. Wind plants and using wind compared with other renewable methods like solar energy has less ration of primary cost to generating energy amount and has been highly considered. It has caused that in many advanced countries in this filed like Denmark and German, approximately 30% of total electrical energy is supplied using wind plants(Karrari et al. 2003).

Sarvari et el. (2012) based on their study regarding a control method applied for static compensator (STATCOM) using PSO algorithm in the systems connected to wind energy to

improve power quality, asserted that wind energy is the most important renewable energy used highly in power systems while injecting wind energy into a grid affects power quality. They also investigated the problems due to installing wind turbines and non-linear loads to power systems using STATCOM connected to an energy saving system (BESS)(Sannino, 2004). A new control scheme using PSO is presented for static compensator. MATLAB/SIMULINK software has been used to simulate static compensator control scheme within the grid-connected system which generates wind energy in order to improve power quality, intended grid, non-linear load, and static self-compensator (Tabesh and Iravani, 2006).

Zarourati et al (2012) investigated wind plant's power quality using synchronous generator without gear box. They stated that normally, productivity rate of wind plant inventor is in the range between 20% -30% and it reaches to 60% in few days of year in which wind blows much. The presented scheme suggests that inverter's output coupled to the grid is improved in terms of power quality features in spite of changes in non-linear load and the empty capacity of inverter is also used to increase total control of the plant. In the existing methods, it is done by FACTS devices and reactive power control as well as voltage regulation is done by FACTS. In the project, the act done by FACTS devices is compensated by placing non-linear load in the joint point of non-linear load and inverter with the grid and changing inverter's control algorithm(Han, 2008).

H. P. Tiwari and Gidwani Lata (2011) based on their study conducted on improving power quality in the system inverting wind energy using harmonic filters, asserted that many researchers have considered wind energy in the current grids. They presented a feasible method to achieve optimal use from wind energy using doubly-fed induction generator systems inverting wind energy. Wind grid integration causes some problems with voltage fluctuation and harmonic distortion. The findings indicated the capability of the relation between power and harmonic filters to reduce harmonic distortion. The presented system increased the efficiency of wind energy application(D. Graovac et al. 2007).

Aguirre et al. (2012) conducted a study regarding the analysis and simulating hydrogen-based electronic systems to improve power quality in distribution grids. They referred that the recent hydrogen technologies provide the opportunity of electrical energy exchange through which costs can be decreases and efficiency cab be increased. To move large battery tank in distribution systems especially regarding environment conservation and sustainable development, Hydrogen technology-based electrical systems can be used(Gidwani Lata and Tiwari, 2009). A multi-level tow-direction current source converter is used to connect electrical analyzer to fuel cells in distribution system with low voltage, high efficiency and high reliability. A Hydrogen technology-based system with the capability of storing in high pressure can facilitate power changes in electrical systems using a considerable amount of wind or solar energy. The presented structure has been simulated using MATLAB/SIMULINK software and the results have indicated a desirable behavior by applying this structure(IEC 61400-21, 2001).

Zheng Zeng et al. (2013) based on their comparative study on topology and strategy of controlling multifunction grid-connected inverters to foster power quality, asserted that grid – connected inverters are of distributed generation systems (DGSs) and micro-grids (NGs) ever since these inverters assumed as interface to achieve sustainable distribution and renewable energy sources (DERs). Recently, grid-connected and multifunction inverters (MFGCIs) have been considered due to their advantages of having relationship with urgent services of power quality boost in DGSs and MGs. These converters not only generate DER power but improve power quality in all grid-connected points. It has to take into consideration that these capabilities can be classified optimally in the same device so that can boost the feature of using grid-connected inverters significantly (Bialasiewicz and Muljadi, 2006). Additionally, grid-connected inverters compared

with multiple devices with independent applications decrease the amount and volume of investing. MFGCI is appropriate for DGSs and MGs applications due to their good performance and advantages. The present study has been investigated topology and strategies associated to MFGCI in details (Mihet-Popa et al. 2004).

### **Main body**

In wind plants sites, inductive machines are mostly used as generator. Since inductive generators such as synchronous faces with sustainability problem, it is important to evaluate the problem of their connection to grid as well (Melgoza, et al. 2001). Most of the connected –grid wind turbines use fixed-speed turbines but variable-speed wind turbines are increasingly used all around the world. The advantage of variable-speed wind turbines is their high output power and regularizing as well as their high power quality. Today, wind turbine generators make use of both synchronous and asynchronous generators with their own merits and defects (Melgoza, et al. 2001).

Variable-speed wind systems deliver 20 to 30 percent of energy more than fixed-speed turbines. Moreover, they decrease power fluctuation and improve reactive power supply. To achieve the maximum power in different speeds of wind, turbine's speed should be variable in a vast range. Selecting the type of generator depends on various factors including performance, machine features, maintaining, and price.

In the present study evaluating the methods of improving the quality of inverters of wind plants, “space vector pulse width modulation”, “using STATCOM” and “using UPQS” to improve power quality have been discussed (Miguel Aguirre, 2012).

Now days, renewable energy sources have been considered by researchers due to the limited fossil fuels and the resulted environmental pollutants. Meanwhile, wind energy has widely been utilized. Integrating wind energy within power systems minimizes their effects in environment while connecting wind generation systems within power systems causes technical challenges such as the problems related to power quality, voltage regulation and sustainability that power quality is of highest importance. Hence, the present study investigates power quality improvement methods (Purkait and Srirama kavacham, 2006).

### **The research hypotheses**

The research main objective is to evaluate the quality improvement methods regarding output power of wind plants' inverters.

The secondary objectives of the study are as follows:

1. Evaluating space vector pulse width modulation to improve power quality
2. Evaluating STATCOM use to improve power quality
3. Evaluating UPQS use to improve power quality

### **Materials and methods**

The present study has used library method to collect data about internal and external related literature. The data has been gathered by studying other researchers' works, specialized and related magazines. The research has studied the comparative-analytic methods of improving the quality of inverters of wind plants.

### **Discussion and results**

#### ***Using STATCOM to improve power quality***

Applying inductive machine as a generator, especially at the level of low power and small plants used in regions far from global network like wind plant to providing power to remote villages

Openly accessible at <http://www.european-science.com>

in which constructing transmission and post lines of distribution is not affordable have highly been considered while inductive machine has some problems including voltage control, frequency, reactive power, load fluctuations, as well as problems related to power quality in spite of its all advantages such as not needing to protective consideration and complex repairs relative to synchronous generators. As asynchronous machine works like a generator, its required magnetic current (reactive) is supplied through two ways including grid-connected case and spontaneous case. The current is provided through the grid in the former case and through capacitor bank in the latter case. However, capacitor even in the first case can lead to decrease transmission line current leading to decrease losses and improving voltage regression. The considerable point in this case is that the amount of the power obtained by asynchronous machine from the grid in generating case is more than engine case for each specific; and the machine's reactive power obtained from the grid is increased by increasing productive reactive power and its least amount is in synchronous speed (Karki, Hu, Bilinton, 2006).

It has to note that the amount of reactive power attracted from the grid by asynchronous generators might exceed, and this unfavorable feature is an unnecessary impose to the grid and asynchronous units connected it and may weaken the system in terms of voltage regulation conditions. Up to now, aid equipment and FACTS devices have been applied as reactive power compensator to diminish power quality problems in joint point of the inverter to the grid and approach to power quality standards. To omit this phenomenon, required reactive power of each asynchronous generator should be compensated locally. Since the amount of reactive power generated by capacitor depends on the generator terminal and its value cannot be changed continuously, variable values of reactive power is needed in various loading conditions to stabilize frequency and range of the voltage; and it makes applying variable sources reactive power such as FACTS equipment i.e. SVC and STATCOM necessary (Sharad et al. 2011).

The most common method of modeling aerodynamic aspects in wind turbines is to apply power curves (torque).

#### ***Static compensator and energy storage system***

Battery energy storage system as an energy storing element is applied to regulate voltage and it is recommended to be connected through DC capacitor in parallel to static compensator (Han et al. 2008; Bhatia et al. 2006). Energy storage system fixes two sides of DC capacitor with charging and de-charging the voltage. Static compensator is a three-phase voltage source inverter injecting compensating current into common joint point. Static compensator output is different with respect to control strategy. In fact, control strategy determines the compensator's performance. Therefore, control scheme of static compensator is of high importance (Mohod and Aware, 2010).

#### **Control scheme of static compensator**

The control scheme approach is based on injecting current into the grid. Voltage and current of two sides of DC capacitor are the necessary parameters for static compensator controller and the controller should give appropriate switching signal for static compensator performance till the static compensator can improve waveform of current and power quality by injecting current.

Figure 1 shows a grid structure to improve power quality in the point of common connection (PCC). The grid includes wind energy production system and wind energy storage system with static compensator and non-linear load. Figure 2 indicates a control scheme to produce appropriate switching signal for static compensator (Thomas Ackerman, 2005).

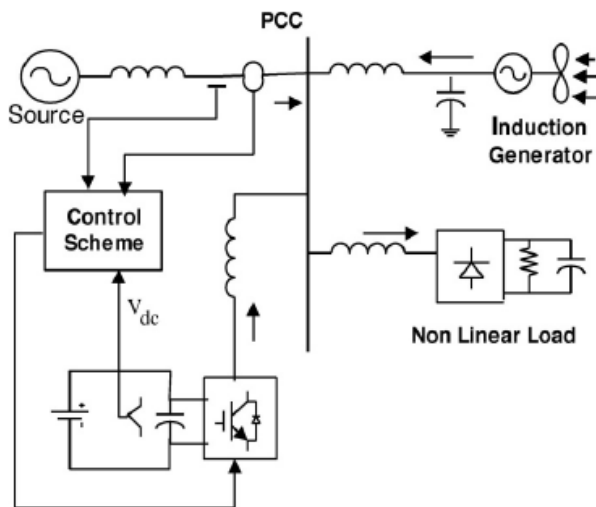


Figure 1. The structure of a grid to improve power quality (Mohod and Aware, 2012)

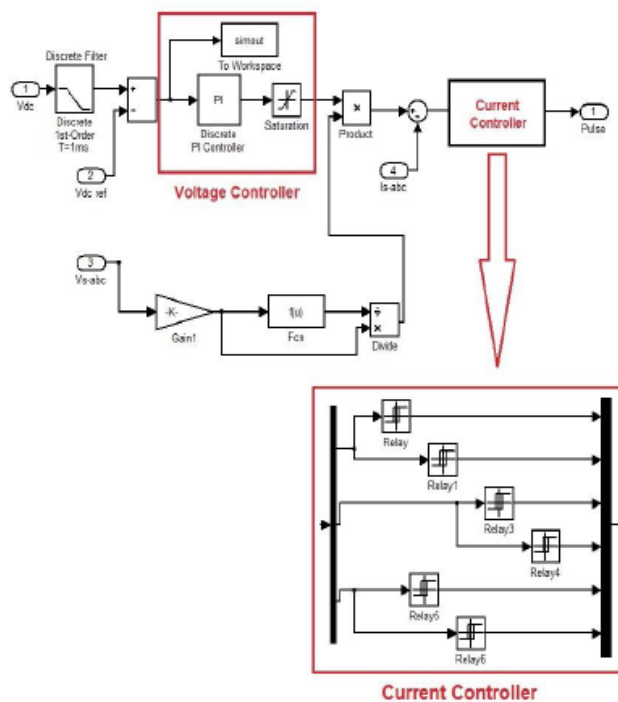


Figure 2. STATCOM controller

The blocks pertained to the voltage and the current controllers are the important blocks shown in the control scheme.

### Using UPQS to improve power quality

Using UPQS is one of the methods of improving power quality. The studies done by research centers like EPRI indicate that a 25% of electrical energy generated by DG will be used up to 2030. These units are connected to a distribution grid or consumer directly and creating sources of generating reactive power is their primary goal. Using DG in low pressure and average pressure distribution grid can cause some problems regarding power quality of these grids such as creating

harmonic and fluctuation in voltage waveform and grid current. Moreover, with respect to increasing non-linear loads in distribution grid, it is necessary to improve power quality and increasing reliability of the grid from accurate performance of industrial processes, especially for sensitive loads.

Using filters improving power quality is a method of improving power quality and diminishing harmonics of distribution grid's voltage and current. To improve power quality, traditional passive filters are selected in such a way that provides the possibility to delete a specific harmonic with a harmonic width. Low price of these filters is the most important merit of passive filters. But they have also some disadvantages including the possibility of intensifying harmonics due to series and parallel resonance between filter impedance and source impedance, the need of a passive filter to omit each specific harmonic, and inflexibility of passive filters against load changes.

Passive filter is of systems which have highly been considered both theoretically and practically during two last decades and is applied by using power electronic converter to compensate harmonic currents and their imbalance in parallel compound and voltage harmonics and their imbalance in series compound. Each of the series and parallel filters cannot completely compensate all power quality parameters by themselves. Therefore, a compound of series and parallel filter can be used through a DC link namely UPQC as a solution. This compound can compensate harmonic currents and non-linear loads imbalance as well as satisfy power supply imbalance (Thiringer, 2002).

Adding a controlled rectifier (parallel reactive power converter) to UPQC results in another compound namely UPQS making control circuit of DC link voltage independent as well as decreasing power range of inverter's parallel filter and compensating all parameters pertained to power quality such as reactive current, imbalance and harmonic of load current, disconnection, shortage, and imbalance. Hence, UPQS is appropriate to be installed in PCC.

In table 1, load effects/ grid and grid/ load have been estimated (Graovac et al. 2007).

**Table 1. Parameters of grid's and load's power quality**

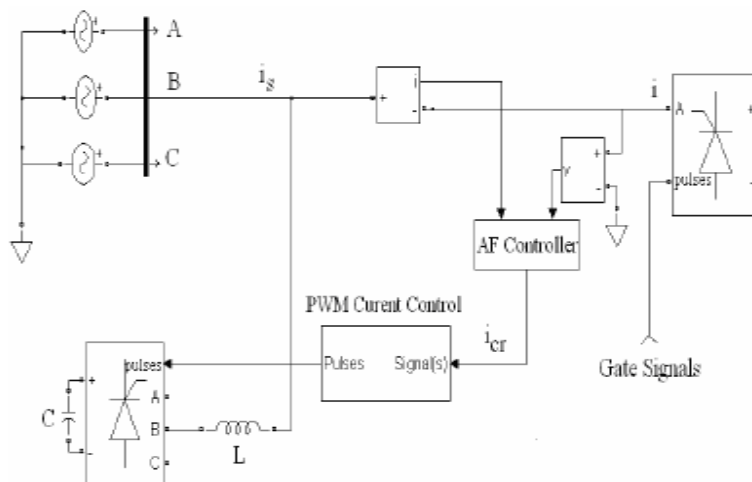
Grid → load	Load → grid
Shortage/abundance	Current harmonic
Voltage imbalance	Reactive current
Voltage distortion	Current imbalance
Voltage disconnection	Fracture voltage
Voltage fluctuation	Voltage flicker

### ***Types of active filters***

An active filter consists of two distinct parts including a power circuit and an active filter controller. Figure 3 shows a parallel active filter in the form of single-line circuit consisted of two above mentioned parts. Parallel active filter samples load current 'i' and load terminal voltage 'v' continuously and computes the values of reference compensator currents "i<sub>cr</sub>". Based on this reference source, power converter switches are recommended by controlling PWM current.

The higher the speed of PWM converter switching is, the more precise reconstructing the compensator current will be so that if the frequency of highest harmonic of load current is "f<sub>hlmax</sub>" the frequency of PWM (f<sub>pwm</sub>) should be more than 10 times of "f<sub>hlmax</sub>".

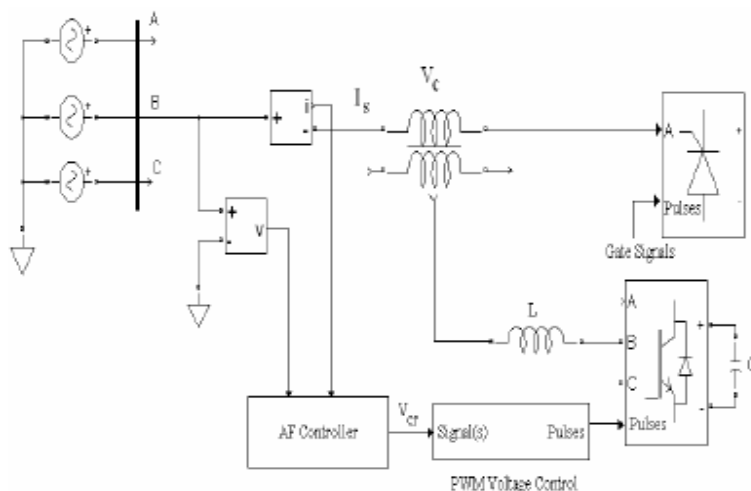




**Figure 3. Single line circuit of base compound of parallel active filter**

If the switching speed of PWM converter is high, compensator current will include high frequency harmonics. These harmonics can be omitted easily by a small high pass filter. In other words, in an ideal condition, PWM converter can be considered as a strong linear amplifier in which compensator current follows reference current.

Series power active filters are applied to compensate voltage and are considered as double parallel active filter in compensating the current. Figure f indicates an overall compound of a series active filter in the form of a single line circuit(Qiao and Harley, 2007).



**Figure 4. Single line circuit of base compound of series active filter**

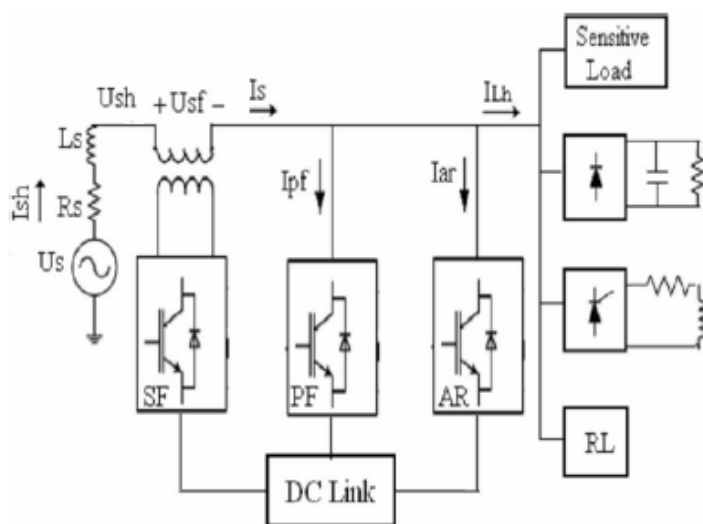
Active filters are still developing. Series active filter sample voltages of phase  $V_R$  continuously in the form of a control ring and compute reference voltages of  $V_{cr}$  for PWM converter with respect to the lines of samples current. In an ideal condition, PWM converter can be considered as a strong linear amplifier so that compensator voltage of  $V_c$  follows reference current " $V_{cr}$ ". The task of  $V_c$  is to compensate  $V_s$  to make  $V_R$  balance and harmonic free.

**UPQS structure**

Using series active filters allow omitting distortions of source voltage and load current of voltage type. In this case, DC capacitor should be charged for series active filter voltage regulator. If

diode rectifier is used to this purpose, shortage voltage can be compensated only. In the structure of UPQC, parallel active filter regulates DC capacitor's voltage. Parallel active filter should have high ranged power elements due to the fact that DC capacitor should be charged. To solve this problem in UPQS structure, figure 5 is recommended. Power quality integrated optimizer consists of three main parts including (Zheng Zeng et al. 2004):

- Active rectifier (AR): it is used to exchange active power and control DC link voltage.
- Series active filter (SF): it omits source voltage harmonics. Voltage shortage and abundance and makes harmonics derived from rectified capacitor load to pass parallel active filter.
- Parallel active filter (PF): it omits load current harmonics and compensates its power coefficient.



**Figure 5. UPQS structure**

### Conclusion

It has been also revealed that using UPQS is one of the methods improving power quality. Using DG systems in low-pressure and average-pressure distribution grids can lead to some problems in the grids' power quality which can be solved by creating harmonic and fluctuation in voltage waveform and grid current. Using power quality improvement filters is one of the methods of power quality improvement as well as solving existing harmonics in the distribution grid current and voltage. Active filters are of the systems which have highly been considered during the last two decades and are applied to compensate the current harmonics and imbalance of parallel compound and harmonic voltage as well as its imbalance in serial compound using power electronic inverters. Based on the research findings, space vector pulse width modulation (SVPWM) is the most effective methods to decrease harmonic output voltage distortion factor. Usually, multi-level inverters are used to compensate the voltage and current limitations of power electronic devices. Controllability complexity, increasing the number of power electronic devices and imbalance of the capacitors' voltage during charging and de-charging are of the defects of increasing the number of inverters'



levels. Various switching patterns of three-level modulation of SVPW can make the output voltage appropriate in terms of above mentioned functions. On the other hand, generating power and voltage of wind generators undergo variations and fluctuations due to aero-elastic phenomena governing wind turbines such as yaw, wind shear and mechanical vibration.

### References

- Amin, M.M.N., Miami, FL, Mohammed, O.A. (2010). Power quality improvement of grid-connected wind energy conversion system for optimum utilization of variable speed wind turbines. IECON - 36th Annual Conference on IEEE Industrial Electronics Society, 3287 – 3292.
- Arulampalam, A., Barnes, M., Jenkins, N. and Ekanayake, J.(2006). Power quality and stability improvement of a wind farm using STATCOM supported with hybrid battery energy storage, IEE Proc.-Gener. Transm. Distrib., 153(6), 701–710.
- Bhatia, R. S., Jain, S. P., Jain, D. K. and B.singh (2006). Battery energy storage system for power conditioning of renewable energy sources, In Proc. Int. Conf. Power electron drives system, 1, 501-506.
- Bialasiewicz, J. T., Muljadi, E. (2006). Analysis of renewable-energy systems using rpm-sim simulator, IEEE Trans. on Industrial Electronics, 53(4), 1137–1143.
- Graovac, D., Katic, V. A. and A. Rufer (2007). Power quality problems compensation with universal power quality conditioning system, IEEE Trans. Power Del.
- Gidwani Lata and H.P. Tiwari (2011). Improving Power Quality of Wind Energy Conversion System with Harmonic Filters. Improving Power Quality of Wind Energy Conversion System with Harmonic Filters. Proceedings of the International Multi-Conference of Engineers and Computer Scientists, Vol II, March 16-181, Hong Kong.
- Han, C., Huang, A. Q., Baran, M., Bhattacharya, S. and W. Litzenberger (2008). STATCOM impact study on the integration of a large wind farm into a weak loop power system, IEEE Trans. Energy Conv., 23(1), 226-232.
- IEC 61400-21(2001). Wind turbine generator systems - Part 21: Measurement and assessment of power quality characteristics of grid connected wind turbines. IEC Standard.
- Karki, R., Hu, P., Bilinton, R.(2006). A simplified wind power generation model for reliability evaluation, IEEE transactions on Energy Conversion, 21(2), 533–540.
- Kwasinski, A. (2003). Time Domain Comparison of Pulse- Width Modulation Schemes, IEEE Power Electronics Letters, 1(3).
- Karrari, A.M., Rosehart, W., Malik, O. P.(2003). Nonlinear modeling and simulation of a wind generation unit for transient and stability analysis, Technical Report University of Calgary.
- Mihet-Popa, L., Blaabjerg, F. and I. Boldea (2004). Wind turbine generating modeling and simulation where rotational speed is the controlled variable, IEEE Transaction on Industry Application, 40(1), 3-10.
- Melgoza, J., Jesus, R., Heydt, G.T, Keyhani, A. (2001). An Algebraic Approach for Identifying Operating Point Dependent Parameters of Synchronous Machine Using Orthogonal Series Expansions, IEEE Transactions On Energy Conversion, 16(1), 92-98.
- Melgoza, J., Heydt, G.T., Keyhani, A., Agrawal, B.L., Selin, D.(2001). Synchronous Machine Parameter Estimation Using Hartley Series, IEEE Transactions On Energy Conversion, 16(1), 49-54.
- Miguel, Aguirre, Hernán, Couto, María Inés, Valla (2012). Analysis and simulation of a hydrogen based electric system to improve power quality in distributed grids. International Journal of Hydrogen Energy. 37(19), 14959–14965. www.sciencedirect.com.

- Mohod, S. W, Aware, M. V. (2010). A STATCOM Control scheme for Grid connected wind energy system for power quality improvement, *IEEE System Journal*, 4(3).
- Purkait, P., Sriramakavacham, R. S. (2006). A New Generalized Space Vector Modulation Algorithm for Neutral point clamped Multilevel Converters, *Progress in Electromagnetic Research Symposium*, Cambridge, USA, pp. 26-29.
- Qiao, W. and R. G. Harley (2007). Power quality and dynamic performance improvement of wind farms using a STATCOM, in *IEEE Power Electronics Specialists Conference (PESC'07)*, Orlando, USA, pp. 1832–1838.
- Sannino, A. (2004). Global power systems for sustainable development, in *IEEE General Meeting*, Denver, CO.
- Sharad, W. Mohod; Mohan, V. Aware.(2011). Power Quality Issues and its Improvement in Wind Energy Generation Interface to Grid System. *MIT International Journal of Electrical and Instrumentation Engineering*,1(2), 116-122.
- Tabesh, A. and Iravani, R. (2006). Small-signal dynamic model and analysis of a fixed-speed wind farm a frequency response approach, *IEEE Trans. On Power Delivery*, 21(2), 778–787.
- Thomas Ackerman (2005). *Wind power in power systems*, John Wiley & Sons.
- Thiringer, T. (2002). Modeling of wind turbines for power system studies, *IEEE Transaction on Power Systems*, 17(4), 1132-1139.
- Zheng Zeng, Huan Yang , Rongxiang Zhao,Chong Cheng (2013). Topologies and control strategies of multi-functional grid-connected inverters for power quality enhancement: A comprehensive review. *Renewable and Sustainable Energy Reviews*, 24, 223–270. [www.sciencedirect.com](http://www.sciencedirect.com).