

Effect of organizational factors on knowledge management in education: A case study in West Mazandaran Province, Departments of Education

Farshad Bozorgi ¹, Mehdi Rouhi Khalili ², Mehdi Amouzad Khalili ³

¹ Financial Trends, Chalos Branch, Islamic Azad University, Chalos, Iran; ² Human Resources Trends, Tehran University, Iran;

³ Strategic Trends, Ayatollah Amoli Science and Research Branch, Islamic Azad University, Iran

Received for publication: 02 August 2013.

Accepted for publication: 07 October 2013.

Abstract

Culture influences all the organizations activities. On the other hand, due to the role and importance of knowledge management in obtaining competitive advantages, understanding the amount of support of organizational culture, especially dominant dimension of culture, is among strategies of knowledge management which are so much important and critical. For this purpose the current study has been conducted on managers and staff of West Mazandaran province Departments of Education. Based on Cochran relationship, 385 managers and staff of the mentioned departments have been selected randomly. The type of research is applied and is descriptive and survey from the point of view of data collection manner. The measuring tool is standard questionnaire of organizational culture factors and standard questionnaire of knowledge management which validity have been confirmed through content analysis by experts and their reliability have been confirmed with the use of Cronbach's alpha. The results of structural models fit between the dimensions of knowledge management and organizational culture indicate that there is a significant relationship between organizational culture dimensions and knowledge management in West Mazandaran province Departments of Education and hence the effectiveness of organizational culture on knowledge management is accepted. Also three dimensions of innovation, job challenge and communications among all the organizational cul-

ture dimensions have the most effect on knowledge management process, which indicates the importance of these elements. Finally, with determining the effective factors on knowledge management the necessary recommendations in line with knowledge management process implementation have been provided.

Keywords: knowledge management, organizational culture, department of education

Introduction

The ever-changing world of today required organizations to search for new and novel tools for their survival and growth. One of the tools which can help organizations in securing these aims is knowledge management. Knowledge of human capitals is one of the most important organizational capabilities and qualifications and maybe we can say that it is the basis and root of all competitive advantages (Hitt&Hoskisson, 2005). Knowledge management can improve an extensive range of organizational performance characteristics with enabling the organization's "more intelligent performance" (Wig, 1999, p. 4). In the current age having information and knowledge management have become a stable situation for survival in dynamic and innovative organizations, and even competitive ability in markets and business is subjected to obtaining, developing and updating individual and organizational knowledge. In the current age, competitive advantage is

Corresponding author: Mehdi Rouhi Khalili, Human Resources Trends, Tehran University, Iran. E-mail: Karafarin2007@yahoo.com.

not achieved only by obtaining information, but also through creating and obtaining new obtainable knowledge (Davenport and Prosa, 1998). But this is not sufficient, because in order for knowledge management to be useful, it is required to be coordinated with the existing organizational culture. A weak organizational culture will prevent individuals, who are trying to maintain their personal power base and self-performance, to share and distribute their knowledge (Kalseth, 2000, p. 11). With analyzing manager's reactions in dealing with phenomena and effective tools in creating competitive advantage, often fascination, frustration, and ultimately wisdom paths are trodden. The manager's look toward the knowledge should not be as a tool for solving all the problems of the organization but they should look at it as an effective and impressive tool related to other organization's topics, i.e. a rational and logical look (Hassanzadeh, 2011). One of the most and effective important topics in organizational activities is the organizational culture. Culture affects everything in an organization and this effect includes knowledge management and its strategies. Nonaka & Takeuchi (1995) believes that "knowledge contrary to information is related to beliefs and commitments". In other words, the current knowledge power for organization, selection, evaluation and decision making is derived mostly from beliefs, not from information and logic and we all know that beliefs and commitments create and form organizational culture. Although culture in itself is not an answer to complexities of knowledge management (Firestone and McElroy, 2008, p. 284), but it can be considered as the most explicit success element and at the same time the most difficult condition for success in a knowledge design (Davenport, 2000, p. 149). Since the ministry of education has the heavy duty of educating and intellectual guiding of the society; hence conducting a research for studying the effect of organizational culture factors on knowledge management in Departments of Education which is one of the key essential organizations; because knowledge management in a proper bed of organizational culture in the current situation can help to improve the performance and success level of this organization as much as possible. Therefore, the main question of this study is: "What are the effects of organizational culture factors on knowledge management in West Mazandaran province Departments of Education?"

Concepts and research framework

Some studies indicate the role of "organizational culture" as the most important and effective factor in establishing "knowledge management" (Mousakhani *et al.*, 2010). Khalifa & Liu (2003) also have emphasized the importance of knowledge management strategy and organizational culture in terms of Knowledge Management Success Model. In a study conducted by Mathi (2004) in Germany, he has named culture as one of the key effective factors on knowledge management. In the meantime, knowledge management as a structure consisting of different layers, deals with different aspects and angles of organization, such as influencing and getting influence from organizational culture, production innovation and sharing knowledge, providing strategies and resources and monitoring continuous knowledge management processes (Za'feraniyan *et al.*, 2008).

Culture has a lasting impact on organizational life, but organization's employees often don't understand this important matter (Pierce & Robinson, 2010, p. 424). Denison (1990) believes that organizational culture is same as principle values, beliefs and code of conduct which play a fundamental role for organizational management system. Christensen and Gordon (1999) believe that organizational culture is something which is maintained uniquely in every organization. Organizational culture has begun from organizational adaptation and ends to meeting environmental needs. Most of organizations have one dominant and multiple secondary cultures (Robins, 1999, p. 375). From the point of view of Sorensen (2002), organizational culture is a system of values and ethical standards representing attitudes and specific behaviors of employees of each organization. Based on him an organization will have a strong culture when these values and ethical standards have encompassed the whole organization. Davidson (2004), defines organizational culture as a pattern of basic assumptions of an organization which have been developed gradually by a group for dealing with problems, adapting with external environment and creating organizational coordination and integration and which are having high reliability, in such a way that this behavioral pattern teaches the new members the correct ways of understanding, thinking and feeling. There are underlying beliefs which individuals learn in a shared manner and based their daily behaviors

on them that create culture – the essence of culture (Shine, 200, p. 50).

So many studies indicate that organizational culture is a critical factor which affects knowledge management (Gold, 2001). Each organization, at the moment it is established will fertilize the embryo of organizational culture inside itself (Khawrazmi, 1992, p. 16). According to Lang (1997) organizational culture defines the value of knowledge and describes the advantage of creating knowledge in an organization. In his view developing a strong culture is so much important in accessing knowledge and processes of accepting knowledge management by the organization (Tsang Ho, 2008, p. 102). Knowledge management is considered as an important resource in creating competitive advantage and in the current competitive situation, effective factors on organizations success are not only related to capital, work force and raw material; but also it is dependent on the ability of the organization in creating knowledge among all the members of the organization (Tsang Ho, 2008, p. 98). In 1930 and 1940 both Elton Mayo and Chester Barnard emphasized on importance of work group norms, feelings, values, actions and reactions occurred in the workplace with explaining nature and informal functions of the organization (Seyed Abbas Zadegan, 1992, pp. 48-49). They consider the efforts done in 1940s around human relationships, 1950s around management based on target, 1960s around organizational structure, 1970s around organizational strategy, 1980s around quality cycles and work team as aspects of organizational culture and introduces them for improving organizations' performance and consider organizational culture as a social driving energy of organizations.

Regarding the field of knowledge management in organizations, Druker and Estrasman have emphasized on the importance of information and explicit knowledge as organizational resources. Organizations for realizing their aims have multiple resources and assets. Some of these resources and assets are so much valuable and unique and have central role in obtaining competitive advantage. "knowledge" is one of these items in a way that they see knowledge as an ultimate substitute for production, wealth and money capital (Tofler, 1998). Also, Peter Druker (1993) regarding the knowledge importance in an organization, doesn't consider knowledge as a resource similar and in line with other resources such as work, capital and land but considers it as the sole and main competitive resource of the

current age" (Nonaka, 1996, p. 833). In fact, knowledge is the only resource that not only its value is not reduced by using it but increases as well (Glaser, 1998). Davenport also believes that investment of an organization on knowledge is more profitable than investment on its materials (Davenport, 1998, p. 14). This knowledge is located and hidden in procedure, instructions, opinions, actions and organizational decisions and when it changes into valuable services and products will gain double importance. Therefore, we can understand that the only sustainable competitive advantage of an organization is first of all what it knows and second with what speed it can apply and use its knowledge (Cohen, 1998, pp 22-39). The raised topics in the knowledge-based society, is that those organizations who wants to be successful in global information society can identify the value of their knowledge and try to expand and develop it (Rowley, 2000). In line with this, there are various organizations that for survival, developing themselves and adapting to changes of the competitive environment around them need to implement knowledge management effectively and if an organization cannot identify required knowledge in its proper place, it will face problem in competitive arenas. With this perspective, knowledge management is a tool which provides the possibility of a more effective use of knowledge in line with the aims and plans of organizations and gives the organization the power to compete (A'rabi & Mousavi, 2010, p. 26). Every practitioner has a different point of view regarding knowledge management, however; still no universal standard comprehensive frame has been established for knowledge management (Metaxiotis *et al.*, 2005).

Davenport (1998) identifies the fundamental dimensions of knowledge management as cultural factors, action process, politics and technology. In another place he name the effective factors on knowledge management as manager support, big decision makers, existence of knowledge-based strategy in organization, creation and development of knowledge-based culture, creation and development of technology infrastructures and the use of knowledge management strategy. In most of the knowledge management patterns they have mentioned to the role of three factors, namely organizational culture factor (Chang Ming U, 2005), technical factor (Metaxiotis *et al.*, 2005) and management factor (Martin & Martin, 2005). In this paper, we study the role of cultural factors and especially organizational culture in knowledge management; because

without considering the cultural factor, the success of knowledge management in organizations is practically impossible. Culture is the heart of a knowledge-based organization. In line with this one of the most important steps is that the culture and attitude of the organization and each of its members will be changed toward knowledge sharing. Organizations in order to applying knowledge management should understand the necessity of creating the knowledge sharing culture among its employees through the process of “internalizing knowledge management”. The importance of this process in an organization is due to the fact the first it will correct the wrong understanding of employees from knowledge management and second helps them in understanding the advantages of sharing knowledge in organization. Studies indicate that the most important barrier of effective implementation of knowledge management in an organization is the lack of knowledge sharing culture and lack of understanding numerous advantages of knowledge management among employees (Chang Ming U, 2005).

Research background

In a study done by Mousakhani et al., (2010), a number of critical prerequisites for successful implementation of knowledge management through providing readiness for knowledge management model have been studied. In this study culture, infrastructure, structure and change management, respectively has been introduced as the most important factors for establishing knowledge management. Rastegar (2009), in his paper, has studied the relationship between organizational culture with knowledge management in Iranian Oil Refining and Distribution Company and the results indicated that organizational culture in this company has a fundamental role in improvement of knowledge management status in this company and the more strong the organizational culture will be, it can result in more improvement in knowledge management status. Hosseini (2006), has studied the relationship between organizational culture and knowledge management establishment in Tarbiat-Modarres University and the results indicate that there is a significant relationship between organizational culture and knowledge management establishment in this university. Gold (2002) have studied the effectiveness of three factors of market (customer, product and competitors), organizational infrastructures (organizational culture, informa-

tion technology and organizational structure) and knowledge processing capacity (capacity of obtaining, creating, saving and applying knowledge) on knowledge management. The results indicate that among the mentioned factors in the model, customer satisfaction in market factors, organizational culture in organizational infrastructures and capacity to applying knowledge in knowledge management processes have the most effect on knowledge management. Also the results of Hang (2005) study indicate that organizational culture, structure and strategy in a combined way have effect on the effectiveness of knowledge management.

Research Purposes

Regarding the purposes of this research, the following can be mentioned:

- Studying the effect of job challenge on knowledge management in West Mazandaran province Departments of Education.
- Studying the effect of communications on knowledge management in West Mazandaran province Departments of Education.
- Studying the effect of innovation on knowledge management in West Mazandaran province Departments of Education.
- Studying the effect of trust on knowledge management in West Mazandaran province Departments of Education.
- Studying the effect of social cohesion on knowledge management in West Mazandaran province Departments of Education.

Research Hypotheses

Main Hypothesis: Organizational culture factors have significant effect on knowledge management in West Mazandaran province Departments of Education.

Secondary Hypotheses:

1. Job challenge has a significant effect on knowledge management in West Mazandaran province Departments of Education.
2. Communications have a significant effect on knowledge management in West Mazandaran province Departments of Education.
3. Innovation has a significant effect on knowledge management in West Mazandaran province Departments of Education.
4. Trust has a significant effect on knowledge management in West Mazandaran province Departments of Education.
5. Social cohesion has a significant effect on

knowledge management in West Mazandaran province Departments of Education.

Methodology

The current research is applied from aim point of view and is descriptive and non-experimental from the point of view of gathering data and information and data analysis and is a survey research from the point of view of conduct method.

Population, sample and data analysis method

The statistical population of the current research includes all the employees of West Mazandaran Departments of Education. Cockron's equation for limited population has been used for determining the minimum required sample volume and 385 employees were considered as the basis of analysis with the use of simple random sampling method. The research data

have been collected with the use of two standard questionnaires of Abraham Carmeli's (2005) organizational culture factors and Bukowitz& Williams (1999) knowledge management. The collected data have been analyzed with the use of Likert scale. For the purpose of data analysis two measures of Pearson's correlation coefficients and structural equations fit with the use of regression models among dimensions have been used to study the effect of each of the subscales of organizational culture on knowledge management process.

Results and Discussion

For the purpose of data analysis, SPSS software Ver. 18 and LISREL Ver. 8.72 have been used and error level of 5% has been determined for testing research hypotheses. The summary of the covariance values among the research variables have been provided in table 1.

Table 1. Covariance matrix of organizational culture and knowledge management variables.

	Knowledge Management	Business Challenge	Communications	Innovation	Trust	Social Cohesion
Knowledge Management	0.63					
Business Challenge	0.60	0.65				
Communications	0.63	0.60	0.73			
Innovation	0.62	0.59	0.61	0.69		
Trust	0.60	0.58	0.60	0.58	0.72	
Social Cohesion	0.63	0.60	0.63	0.61	0.62	0.84

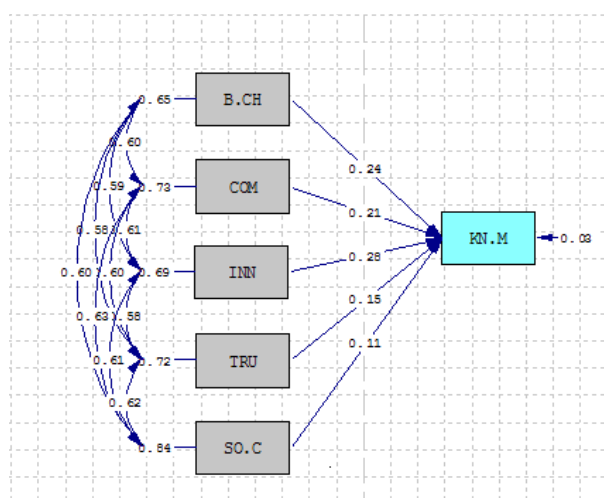

Figure 1. An overview of structural equation of the organizational culture and knowledge management variables.

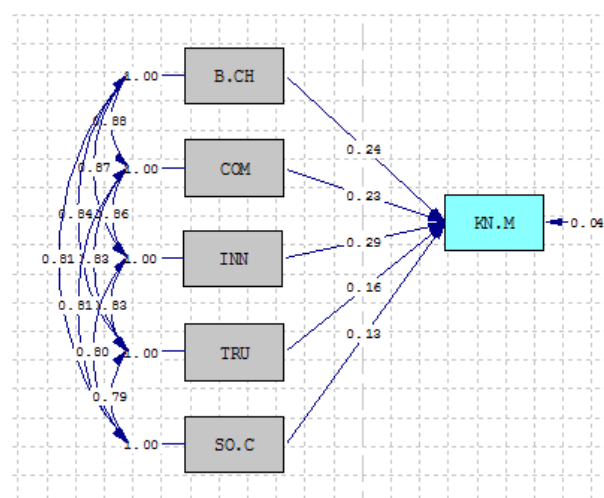

Figure 2. An overview of standard model in structural equation of organizational culture and knowledge management variables.

As it is observed from table 1 and figure 1, which indicate the regression coefficient estimation between knowledge management variable and the factors of organizational culture, innovation element has the most effect on knowledge management. In this figure, B.CH, COM, INN, TRU, SO.C and KN.M represent business challenge, communications, innovation, trust, social cohesion and knowledge management variable, respectively.

In figure 2, which shows the regression coefficients of the standard model, no significant change is occurred in regression coefficients. This indicates that the measurement scale of variables doesn't have significant effect on coefficients estimation.

And finally in figure 3, which evaluates the values of T-Student statistics for significance of the model variables, it is observed that the assumption that all the model variables are significant is accepted in the level of 0.05.

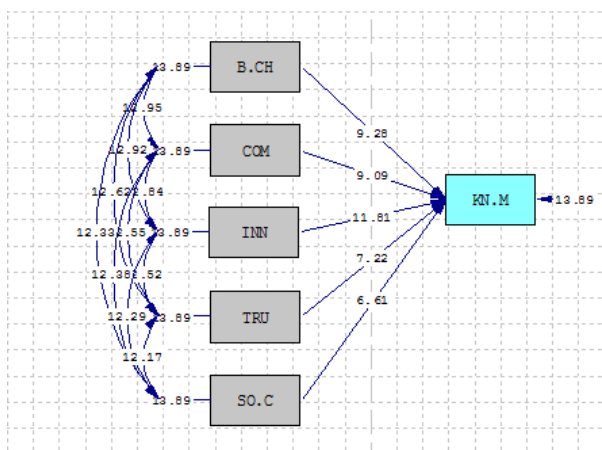

Figure 3. An overview of T-student statistics in structural equation of organizational culture and knowledge management variables.

The value of determination coefficient of regression model and determined revised coefficient together is obtained equal to 0.977. The big size of these coefficients indicates that the fitted regres-

sion model has proper power in predicting the score values of knowledge management. The fact that there is no difference between these two values indicate that the large size of the regression model power is not due to the presence of so many independent variables in the model and as a result all the independent variables which are the same dimensions of organizational culture are effective in obtaining this much of predicting power.

In evaluating goodness of fit of the regression model above, table 2 presents the partial and part (semi-partial) correlation values and Pearson's correlation of independent variables with knowledge management; it is shown that there is a great correlation among independent variables.

Based on comparison of the Pearson's correlation values of variables with dependent variable and partial correlation, it is observed that after omitting the effect of other independent variables from each relevant independent variable, and also omitting their effect from the response variable, the correlation value of the independent variable with dependent variable is reduced significantly. By evaluating the part (semi-partial) correlations which only deletes the linear effects of independent variables from each other and obtains the correlation of each of them with response variable, it can be concluded that there is a great correlation among the dimensions of organizational culture. Since the existence of correlation among independent variables would lead to an increase in the variance of the model's parameters estimation, in order to obtain a model with more accurate parameters' estimation, the standard values (z-scores) of independent variables have been used. The results of the fitness of this model indicate that the estimation of parameters and also the estimation error of the parameters are changes. Due to the fact that the model has been fitted with standard variables and with considering fixed parameter, we are not looking for the changes in the values of the parameters' estimation but for the decrease in the estimations error. Table 3 presents these data.

Table 2. Pearson's correlations, partial and part (semi-partial) variables and regression model estimation error

Variable	Pearson's correlation	Partial correlation	Part (Semi-partial) correlation	Regression model coefficients	Parameters estimation error in the model
Business challenge	.995	.439	.026	.242	.025
Communications	.995	.422	.025	.215	.023
Innovation	.995	.521	.033	.281	.023
Trust	.992	.351	.020	.149	.020
Social cohesion	.989	.319	.018	.114	.017

Table 3. Pearson's correlations, partial, part (semi-partial) variables and estimation error of the regression model parameters after standardizing.

Variable	Pearson's correlation	Partial correlation	Part (Semi-partial) correlation	Regression model coefficients	Parameters estimation error in the model
Business challenge	.931	.427	.097	.192	.021
Communications	.926	.420	.095	.182	.020
Innovation	.932	.515	.123	.231	.020
Trust	.891	.345	.075	.124	.017
Social cohesion	.866	.319	.069	.104	.016

An increase in partial and part (semi-partial) correlation coefficients values indicate that standardizing independent variables have managed to reduce the effective linear correlation between them from the model to some extent. This has also decreased the estimation errors to some extent, which in turn has resulted in increasing the model accuracy. Figure 4 and 5, respectively, evaluate the assumption of normality of the error phrases and the stability of regression error phrase variance.

Normal P-P Plot of Regression Standardized Residual

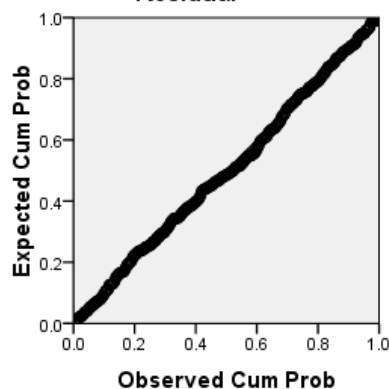

Figure 4. Cumulative distribution of model errors against normal distribution.

Based on figure 4 and considering the fact that experimental distribution of error phrases does not have any distance from normal distribution, the assumption of the normality of the distribution of error phrases is accepted and as a result of figure 5 in which no process is observable between the points, it can be accepted that the variance of the regression error phrases is fixed and hence; the obtained model has the necessary validity.

Now considering that the obtained model has the necessary fitness, we will interpret the amount

of the impact of organizational culture dimensions on knowledge management based on the standardized model coefficients.

The value of the regression coefficients with standardized variables indicate that the innovation element is placed in the 1st rank from the point of view of impact on knowledge management. Job challenge, communications respectively take 2nd and 3rd ranks and trust and social cohesion respectively take 4th and 5th ranks. It is necessary to note that this ranking is obtained after deleting the impacts of the dimensions of organizational culture from each other and the partial correlation coefficients confirm the same result as well.

Scatterplot

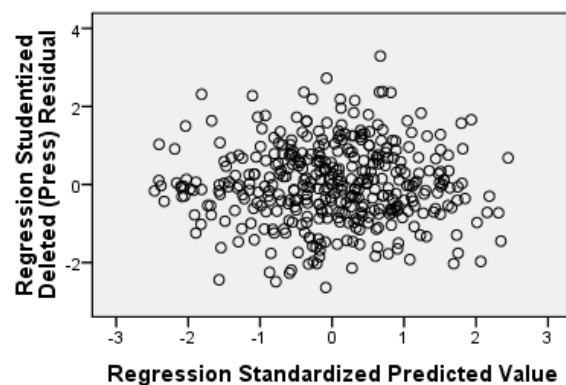

Figure 5. Distribution of the predicted standardized values against adjusted regression errors.

Conclusions

As the results of this research show, organizational culture variable and all its dimensions have a positive and significant effect on knowledge management performance and its establishment. Managers for selecting the proper strategy of knowledge management are required to identify the domi-

nant dimension of culture. For distinguishing the dominant dimension of the culture, first the variables of each of the dimensions of culture should be calculated. Calculation of the variables of organizational culture dimensions in West Mazandaran Departments of Education indicate the high importance of the collection of three variables of “innovation”, “business challenge” and “communications” among other dimensions of organizational culture, considering the amount of their effect on establishment of knowledge management process. Partial and semi-partial correlation coefficient of these dimensions indicate that comparing to two dimensions of “trust” and “social cohesion”, the three mentioned factors having such a large effect on knowledge management process in departments of education that this effect is justifiable comparing to other dimensions up to a negligible extent. This would help the managers of these departments in identifying the current situation and also helps them to reach objectivity in their strategic orientations as well as achieving the organization’s goals. With identifying the powerful effective dimensions, manager of these departments will understand the total capacity of the organization in dealing with different issues including knowledge management. In establishing this conclusion which is consistent with the results of Hasanzadeh (2009), we can say that knowledge management is one of most important human resources with emphasis on organizational culture and team work. It means that a positive and strong organizational culture is critical for promotion of education, development and sharing skills of creating new knowledge (Yamin Firooz, 2003). In addition knowledge management is a abstract concept and the culture of sharing knowledge is dependent on the attitudes of individuals who have created this culture. In case that the employees will not be interested in sharing their knowledge with the other employees of the organization, it would be so much difficult to promote knowledge sharing culture through rule and regulations among them. Therefore according to Moshabacki and Zareie (2003), organizational culture is a sample of the implicit knowledge distributed throughout the organization and the amount that a person understands the organizational culture is a characteristics which distinguishes them from each other; a bed that connects different dimensions of the organization together (Quine, 1999) and which does not occur overnight and accidentally (Trice and Bear, 1993) and differentiates two organizations

from each other. Therefore knowledge management cannot be effective in an organization, in which no significant cultural evolution has happened (Housi, 2004). Therefore, organizations efforts for changing into a knowledge-based organization will only be successful when cultural characteristics required for implementation of knowledge management will be available in it. Knowledge can only be useful when it is created and shared effectively in an organization and when it is supported by the culture of that organization (Wang & Ahmad, 2003). Therefore, it can be said that successful and effective implementation of knowledge management process in West Mazandaran departments of education requires a fundamental cultural revolution in the perspectives of teachers which again requires that specific cultural characteristics would exist in it for knowledge management implementation.

Recommendations

- Considering the research findings, the following recommendations are provided:
 - Adopting knowledge management strategy at the level of Ministry of Education and coordinating it with education and cultural strategies;
 - Enhancing communicational infrastructures at schools level in Mazandaran province;
 - Providing training to teachers, employees and managers of the city regarding information and communicational skills;
 - Holding serving trainings or short period trainings in line with empowerment of them;
 - Holding justification classes or managers and making them familiar with knowledge management concepts and the necessity of its application;
 - Establishing strategies in line with organizational culture for knowledge management through training

References

- A’rabi, S. M. & Mousavi, S. (2010). *Knowledge strategy* (1st edition). Mahkameh Publications, Tehran.
- Brian Quinn, J., Mince Berg, H., & Robert, M. (1994). *Strategic management*, translated by Sabeti, Mohammad, Training Centre for Public Administration Publication.
- Bukowitz, W. & Williams, R. (1999). *Knowledge Management Diagnosis Questionnaire*.
- Cheng, M.Y. (2005). Socializing knowledge management: The influence of the opinion lead-

- er Irandoc, *Scientific Communication Monthly Journal*, 5 (1), 1-6
- Christensen, E. , Gordon, G., (2004). *An exploration of industry, culture and revenue growth*. Retrieved December 21, 2004 Available at <http://oss.sagepub.com/content/20/3/397.abstract>.
- Cohen, S. G., & Bailey, D. E. (1998). What makes teams work: Group effectiveness research from the shop floor to the executive suite, *Journal of Management*, 23 (3), 239-90
- Davenport, T. & Prosa, L. (2000). *Knowledge management*, translated by Hossein Rahmanseresht, Tehran: Sapco publications.
- Davidson, G. (2004), *The relationship between organizational culture and financial performance in the south African investment bank*. Unpublished master's thesis, University of South Africa, Pretoria.
- Denison, D. (1999). *Corporate culture and organizational effectiveness*. New York: John Wiley & Sons.
- Firestone, J. & Mark, M. (2008). *Key issues in new knowledge management*, Translated by Ahmad Ja'farnezhad and Khadijeh Safiri (1st edition). Tehran. Book Institution of Mehraban Nashr Publications.
- Gold, A.H., Malhotra, A. & Segars, A.H. (2001). Knowledge management: An organizational capabilities perspective, *Journal of Management Information Systems*, 18(1), 185-214.
- Hassanzadeh, M. (2009). Studying infrastructure factors of knowledge management in Islamic Republic of Iran government. *Danneshvar Rafter*, 16(36), 11-28.
- Hassanzadeh, M. (2011). *Knowledge management teaching material*. National Defense University.
- Hitt, I., & Hoskisson, B. (2005). *Strategic Management* (6th ed.), Thompson Southwestern.
- Holowzki, A. (2002). The Relationship Between knowledge management and organizational culture. University of Oregon; Applied information management program, December http://findarticles.com/p/articles/mi_m4035/is_1_47/ai_87918557/pg_9. http://www.findarticles.com/p/articles/mi_m4339/is_3_20/ai_57816041/pg_7.
- Husseini, M. (2006). *Studying the relationship between organizational culture and knowledge management in Tarbiat Modarres University*, Tehran: Tarbiat Modarres University.
- Hussi, T. (2004). Reconfiguring knowledge management – combining intellectual capital, intangible assets and knowledge creation. *Journal of Knowledge Management*, 8(2), 36-52.
- Kalseth, K. (2000). Knowledge management strategy. *Perspective Journal*, 37.
- Khalifa, M. & Liu, V. (2003). Determinations of KM Programs. Available at: www.ejkm.com.
- Kroeber, A. and Kluckhohn, C. (1952), *Culture: A Critical Review of Concepts and Definitions*, *Papers of the Peabody Museum of American Archaeology and Ethnology*, 47(1).
- Khawrazmi, Sh. (1992). Organizational culture, *Tadbir Journal*, 22.
- Martin, J. & Marion, R. (2005). Higher education leadership roles in knowledge processing the learning organization. 12(1), 140-151.
- Mathi, K. (2004). *Key success factors for knowledge management*, Master thesis, International Business Management & Consulting: Hochschul Institute Lindau, University of Applied Sciences/FH Kempten. pp. 14-15.
- Metaxiotis, K., Ergazakis, K., Psarras, J. (2005). A Framework for Building Successful Knowledge Cities, in *Knowledge Cities: Approaches, Experiences and Perspectives* edited by Prof. Francisco Carrillo, Elsevier
- Monnavarian, A. & Asghari, N. (2004). *Establishing strategy in knowledge-based economies*, Tehran: 4th international conference of quality management.
- Mousakhani, M., Ajali Gheshlajooghi, M., & Safavi Mir Mahalleh, S.R. (2010). Providing a model for evaluating the amount of organizations readiness in the field of knowledge management (case study: Iran's statistics center). *Journal of Humanities, management research*, 14 (2).
- Nonaka, I. & Takeuchi, H. (1995). *The Knowledge-creating company*, New York: Oxford University Press.
- Pierce, J. & Robinson, R. (2010). *Planning and strategic management*. Translated by Sohrab Khalil-i Shorini.
- Quinn, R. (1999). *Diagnosing culture and changing organizational culture*. New York: Addison Wesley.
- Rastegar, A. (2009). *Studying the relationship of organizational culture with knowledge management in National Iranian Oil Refining and Distribution Company*. Ghom Pardis University.
- Robins, P. S. (1999). *Principles of organizational behavior*, Translated by Ali Parsian and Seyed Mohammad A'rabi (16th edition). Cultural Research Office Publications, Tehran.
- Rowley, C. & Benson, J. (2000) (eds.). *Globalization and Labour in the Asia Pacific*, London: Cass.

- Seyed Abbaszadegan, M.(1992).School in world management, *Management Journal*, 5.
- Shine, E. (2009). *Organizational culture*, Translated by Mohammad EbrahimMahjoob. 2nd edition. Tehran. Fara publications.
- Sorensen, J., (2002), *The strength of corporate culture and reliability of firm performance*.
- Tofler, A. (1998). *Replacement in power*, translated by Shahin Dokht Khawrazmshahi.Tehran: Simorgh Publications.
- Trice, H. & Beyer, J. (1993).*The cultures of work organizations*. Englewood Cliffs, NJ: Prentice Hall.
- Tsang ho , Ch. (2008).*The relation between knowledge management enablers and performance*, National Chung Cheng University.
- Wang, C. & Ahmed, P. (2003).Structure & structural Dimensions for knowledge-Based organizations. *Measuring Business Excellence*, 7 (12), 51-62
- Wig, K. (1999).Successful knowledge management, *European Management Journal*.
- YaminFirooz, M. (2002).Knowledge and knowledge management in organizations.*Book Journal*, 14(1), 97-108.
- Za'farian, R., Esmaeilzadeh, M., &Nesa' Shahi, A.(2008).Providing an implementation pattern of knowledge management in small and medium businesses: A case study in Iran Zamin Oil Company).*Entrepreneurship Development*, 1(2).